



CST25P09L P-Ch 25V Fast Switching MOSFETs

- ★ Green Device Available
- ★ Super Low Gate Charge
- ★ Excellent Cdv/dt effect decline
- ★ Advanced high cell density Trench technology



CST25P09L Product Summary

BVDSS	RDSON	ID
-25V	15mΩ	-9.0A

CST25P09L Description

The CST25P09L is the high cell density trenched P-ch MOSFETs, which provides excellent RDSON and efficiency for most of the small power switching and load switch applications. The CST25P09L meet the RoHS and Green Product requirement with full function reliability approved.

CST25P09L SOT23-3L Pin Configuration

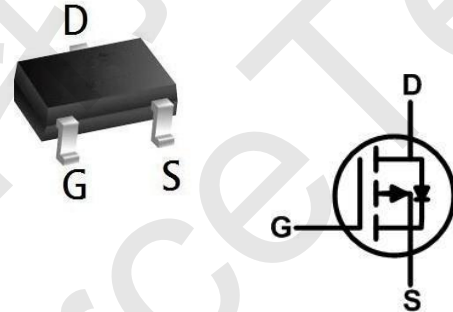

CST25P09L Absolute Maximum Ratings (TA=25°C unless otherwise noted)

Symbol	Parameter	Limit	Unit
V _{DS}	Drain-Source Voltage (V _{GS} =0V)	-25	V
V _{GS}	Gate-Source Voltage (V _{DS} =0V)	±20	V
I _D	Drain Current-Continuous(T _C =25°C)	-9	A
	Drain Current-Continuous(T _C =100°C)	-4.9	A
I _{DM (pluse)}	Drain Current-Continuous@ Current-Pulsed (Note 1)	-31.2	A
P _D	Maximum Power Dissipation(T _C =25°C)	2.4	W
	Maximum Power Dissipation(T _C =100°C)	0.96	W
E _{AS}	Avalanche energy (Note 2)	95	mJ
T _J , T _{STG}	Operating Junction and Storage Temperature Range	-55 To 150	°C

CST25P09L Thermal Characteristic

Symbol	Parameter	Typ	Max	Unit
R _{θJA}	Thermal Resistance, Junction-to-Ambient		52	°C/W



CST25P09L P-Ch 25V Fast Switching MOSFETs

CST25P09L Electrical Characteristics ($T_J=25^\circ\text{C}$ unless otherwise noted)

Symbol	Parameter	Conditions	Min	Typ	Max	Unit
On/Off States						
BV_{DSS}	Drain-Source Breakdown Voltage	$V_{GS}=0V, I_D=-250\mu A$	-25			V
I_{DSS}	Zero Gate Voltage Drain Current	$V_{DS}=-25V, V_{GS}=0V$			-1	μA
I_{GSS}	Gate-Body Leakage Current	$V_{GS}=\pm 12V, V_{DS}=0V$			± 100	nA
$V_{GS(th)}$	Gate Threshold Voltage	$V_{DS}=V_{GS}, I_D=-250\mu A$	-1	-1.2	-2.5	V
$R_{DS(on)}$	Drain-Source On-State Resistance	$V_{GS}=-10V, I_D=-7.5A$		15	20	$m\Omega$
		$V_{GS}=-4.5V, I_D=-5A$		20	26	$m\Omega$
Dynamic Characteristics						
C_{iss}	Input Capacitance	$V_{DS}=-15V, V_{GS}=0V,$ $f=1.0MHz$		1135		pF
C_{oss}	Output Capacitance			184		pF
C_{rss}	Reverse Transfer Capacitance			117		pF
Switching Parameters						
$t_{d(on)}$	Turn-on Delay Time	$V_{GS}=-10V, V_{DS}=-15V,$ $R_L=15\Omega, R_{GEN}=6\Omega$		12		nS
t_r	Turn-on Rise Time			14		nS
$t_{d(off)}$	Turn-Off Delay Time			195		nS
t_f	Turn-Off Fall Time			95		nS
Q_g	Total Gate Charge	$V_{GS}=-10V, V_{DS}=-15V, I_D=-7.5A$		21.7		nC
Q_{gs}	Gate-Source Charge			1.4		nC
Q_{gd}	Gate-Drain Charge			4.1		nC
Source-Drain Diode Characteristics						
I_{SD}	Source-Drain Current (Body Diode)				-9	A
V_{SD}	Forward on Voltage (Note 3)	$V_{GS}=0V, I_S=-7.5A$			-1.2	V
t_{rr}	Reverse Recovery Time	$I_F=-2A, dI/dt=100A/\mu s$		36		ns
Q_{rr}	Reverse Recovery Charge	$I_F=-2A, dI/dt=100A/\mu s$		34		nC

Notes 1.Repetitive Rating: Pulse width limited by maximum junction temperature.

Notes 2.EAS condition: $T_J=25^\circ\text{C}, V_{DS}=30V, V_G=-10V, R_g=25\Omega, L=0.5mH$.

Notes 3.Repetitive Rating: Pulse width limited by maximum junction temperature.



CST25P09L Typical Electrical And Thermal Characteristics (Curves)

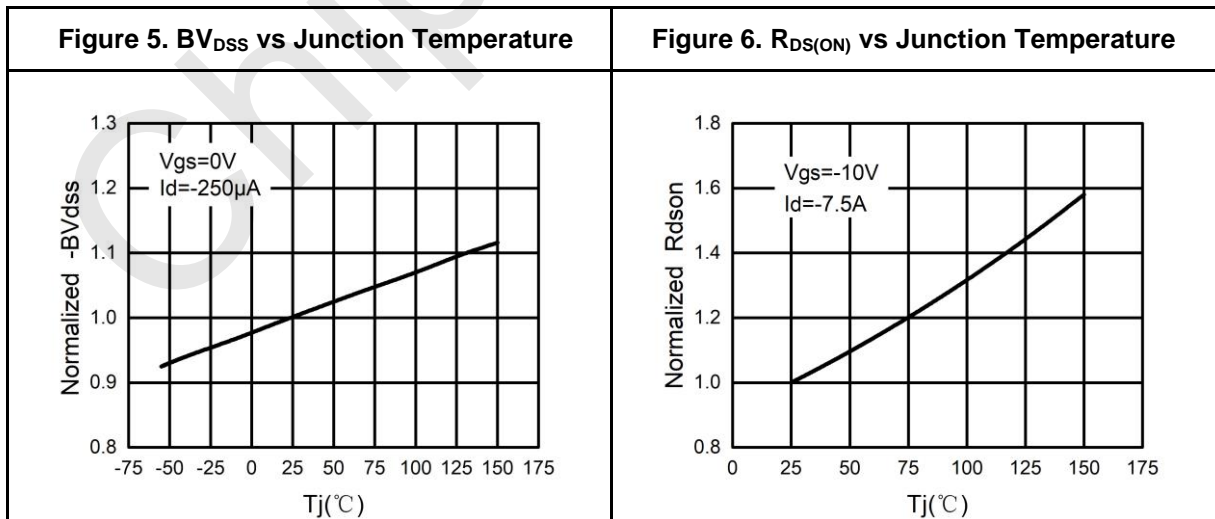
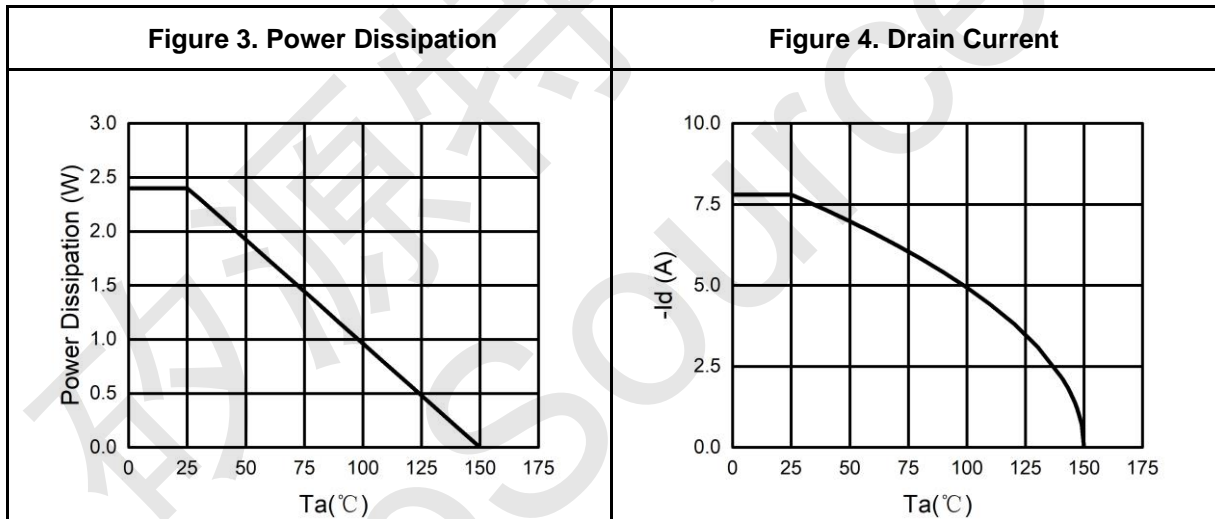
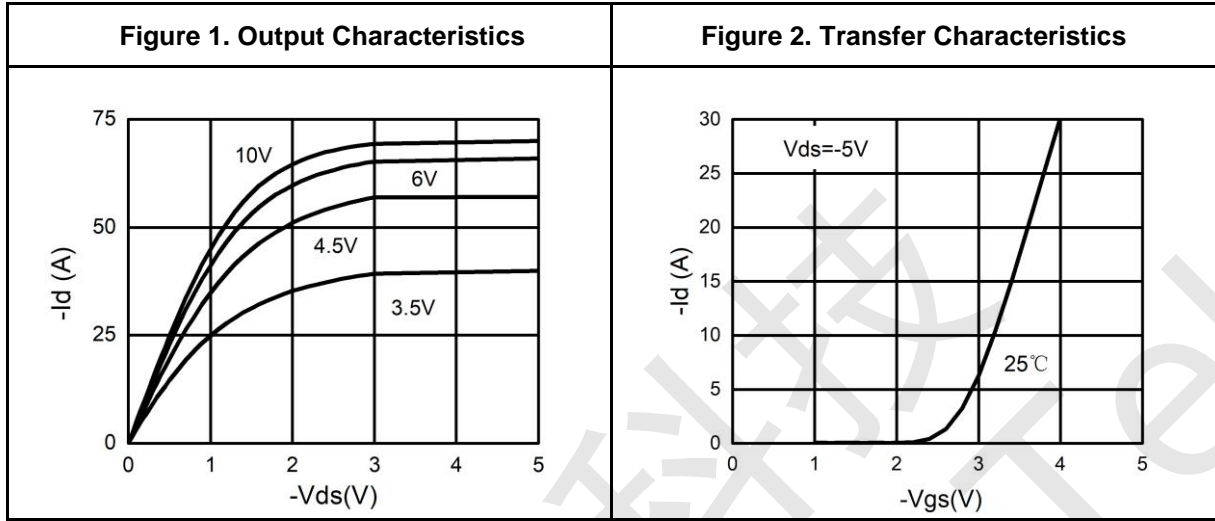

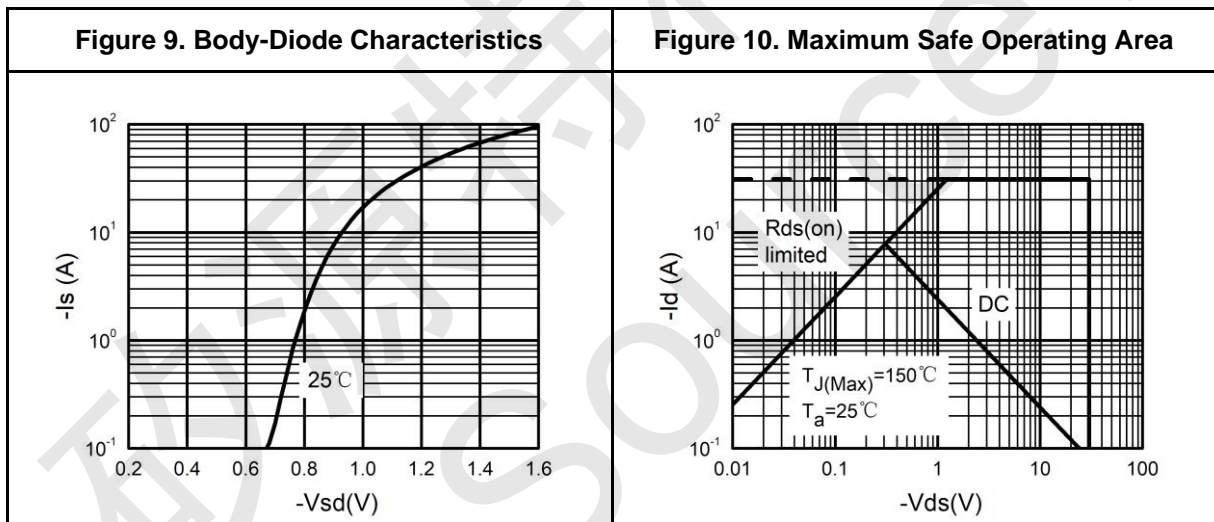
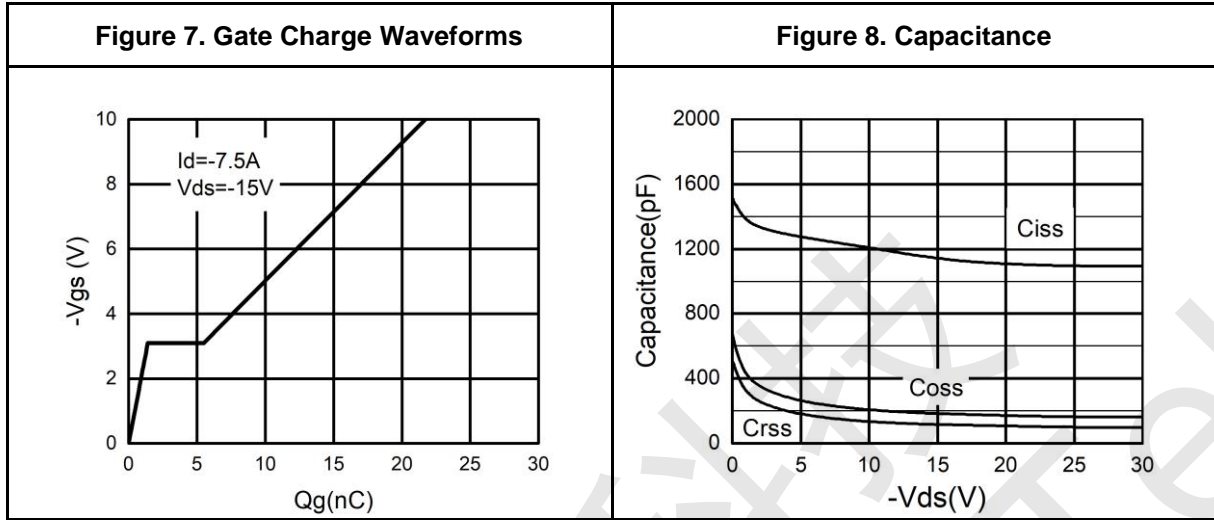



CST25P09L Test Circuit

1) E_{AS} Test Circuits

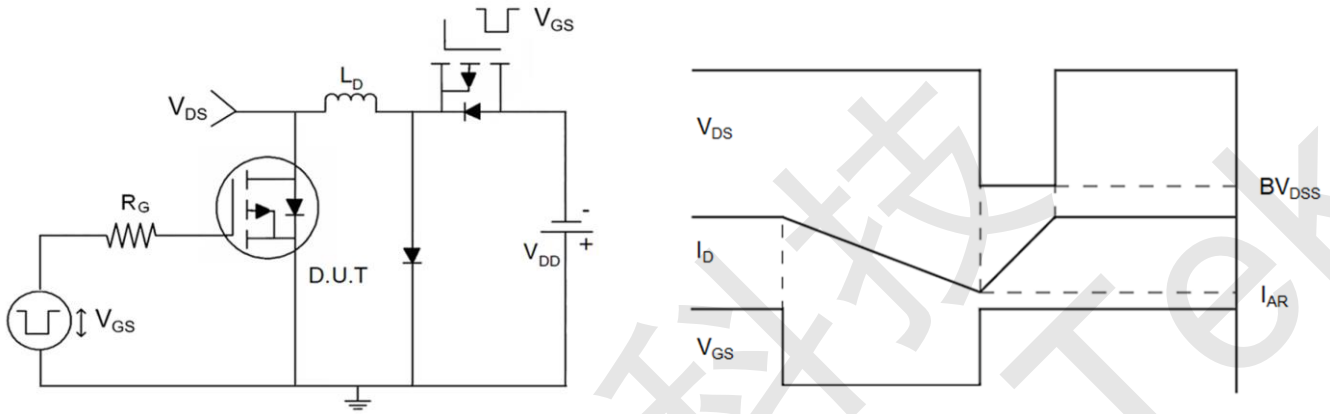

2) Gate Charge Test Circuit

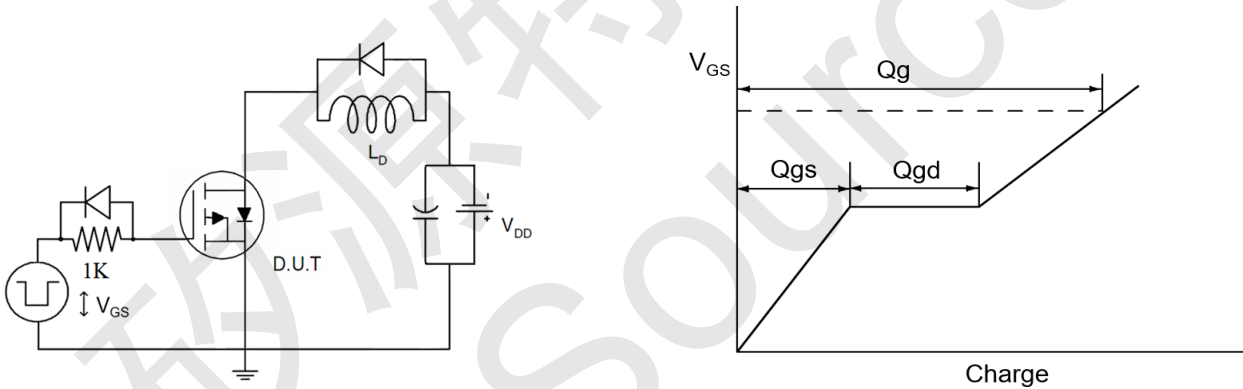

3) Switch Time Test Circuit

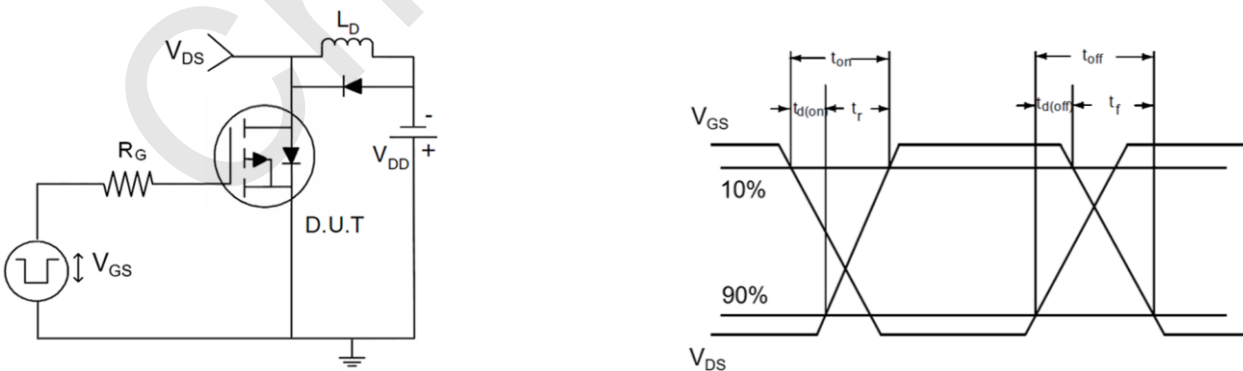



CST25P09L SOT-23-3L Package Information

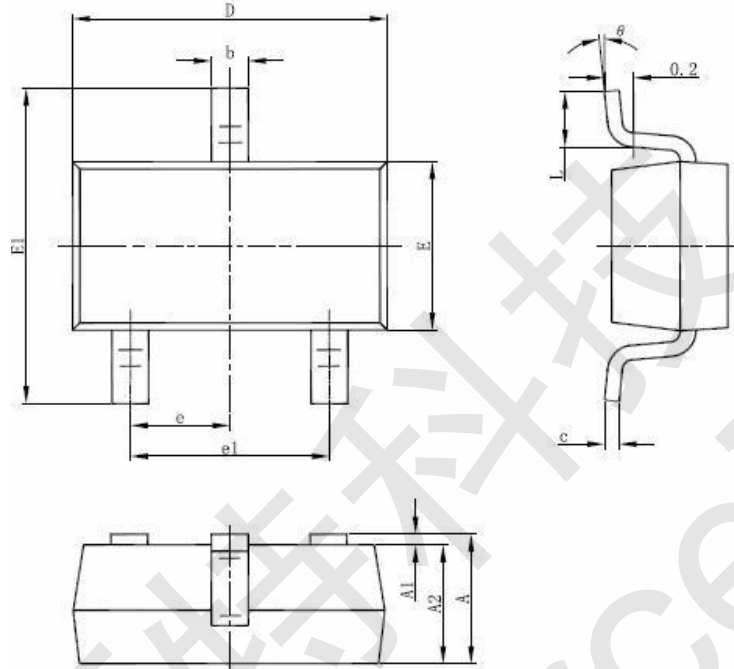

Symbol	Dimensions In Millimeters		Dimensions In Inches	
	Min	Max	Min	Max
A	1.050	1.250	0.041	0.049
A1	0.000	0.100	0.000	0.004
A2	1.050	1.150	0.041	0.045
b	0.300	0.500	0.012	0.020
c	0.100	0.200	0.004	0.008
D	2.820	3.020	0.111	0.119
E	1.500	1.700	0.059	0.067
E1	2.650	2.950	0.104	0.116
e	0.950(BSC)		0.037(BSC)	
e1	1.800	2.000	0.071	0.079
L	0.300	0.600	0.012	0.024
θ	0°	8°	0°	8°