



CST3330M Product Summary

- ★ Green Device Available
- ★ Super Low Gate Charge
- ★ Excellent CdV/dt effect decline
- ★ Advanced high cell density Trench technology

BVDSS	RDS(ON)	ID
20V	5.8mΩ	30A

CST3330M DFN3030-8L Pin Configuration

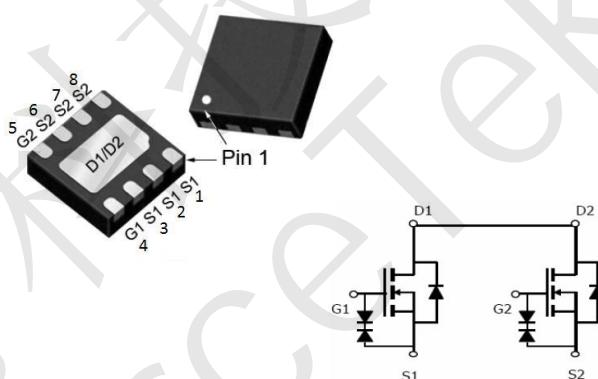

CST3330M FEATURE

- TrenchFET Power MOSFET
- Excellent $R_{DS(on)}$
- Low Gate Charge
- High Power and Current Handling Capability
- Surface Mount Package
- ESD Rating:2000V HBM

CST3330M ABSOLUTE MAXIMUM RATINGS ($T_a=25^{\circ}\text{C}$ unless otherwise noted)

Parameter	Symbol	Value	Unit
Drain-Source Voltage	V_{DS}	20	V
Gate-Source Voltage	V_{GS}	± 12	V
Continuous Drain Current	I_D	30	A
Pulsed Drain Current (note 1)	I_{DM}	100	A
Thermal Resistance from Junction to Ambient (note 2)	$R_{\theta JA}$	38	$^{\circ}\text{C}/\text{W}$
Junction Temperature	T_J	150	$^{\circ}\text{C}$
Storage Temperature	T_{STG}	-55~+150	$^{\circ}\text{C}$
Lead Temperature for Soldering Purposes(1/8" from case for 10 s)	T_L	260	$^{\circ}\text{C}$



CST3330M MOSFET ELECTRICAL CHARACTERISTICS $T_a = 25^\circ\text{C}$ unless otherwise specified

Parameter	Symbol	Test Condition	Min	Typ	Max	Unit
STATIC CHARACTERISTICS						
Drain-source breakdown voltage	$V_{(BR)DSS}$	$V_{GS} = 0V, I_D = 250\mu A$	20			V
Zero gate voltage drain current	I_{DSS}	$V_{DS} = 19V, V_{GS} = 0V$			1	μA
Gate-body leakage current	I_{GSS}	$V_{GS} = \pm 12V, V_{DS} = 0V$			± 7	μA
Gate threshold voltage (note 3)	$V_{GS(th)}$	$V_{DS} = V_{GS}, I_D = 250\mu A$	0.5	0.7	1.0	V
Drain-source on-resistance (note 3)	$R_{DS(on)}$	$V_{GS} = 4.5V, I_D = 8.0A$		5.8	6.6	$m\Omega$
		$V_{GS} = 2.5V, I_D = 6.0A$		6.8	9.5	$m\Omega$
Forward transconductance (note 3)	g_{FS}	$V_{DS} = 5V, I_D = 4A$		10		S
Diode forward voltage (note 3)	V_{SD}	$I_S = 1.50A, V_{GS} = 0V$			1.0	V
DYNAMIC CHARACTERISTICS (note 4)						
Input Capacitance	C_{iss}	$V_{DS} = 10V, V_{GS} = 0V, f = 1MHz$		1827		pF
Output Capacitance	C_{oss}			241.5		pF
Reverse Transfer Capacitance	C_{rss}			225.4		pF
SWITCHING CHARACTERISTICS (note 4)						
Turn-on delay time	$t_{d(on)}$	$V_{GS} = 4.5V, V_{DS} = 10V, I_D = 6A$ $R_{GEN} = 3\Omega$		6.4		ns
Turn-on rise time	t_r			24.5		ns
Turn-off delay time	$t_{d(off)}$			260.4		ns
Turn-off fall time	t_f			143		ns
Total Gate Charge	Q_g	$V_{DS} = 10V, V_{GS} = 4.5V, I_D = 6A$		25.2		nC
Gate-Source Charge	Q_{gs}			2.24		nC
Gate-Drain Charge	Q_{gd}			9.1		nC

Notes :

1. Repetitive rating: Pulse width limited by maximum junction temperature
2. Surface Mounted on FR4 board, $t \leq 10$ sec.
3. Pulse test : Pulse width $\leq 300\mu s$, duty cycle $\leq 2\%$.
4. Guaranteed by design, not subject to production.



CST3330M TYPICAL ELECTRICAL AND THERMAL CHARACTERISTIC

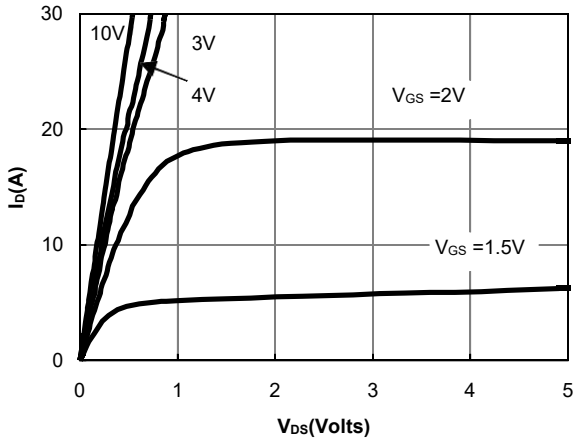

Figure 1: On-Regions Characteristic CS

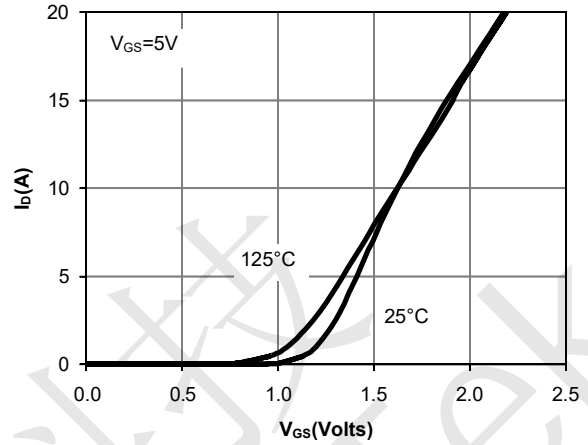

Figure 2: Transfer Characteristics

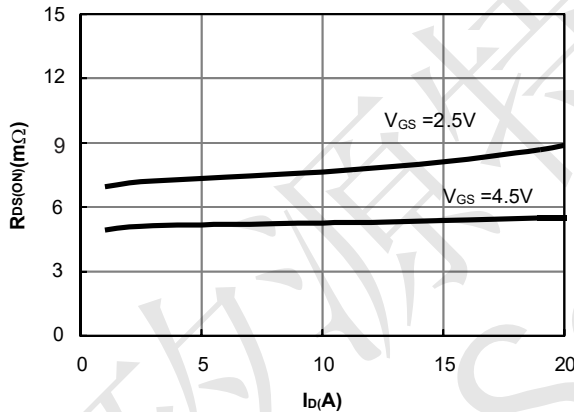

Figure 3: On-Resistance vs. Drain Current and Gate Voltage

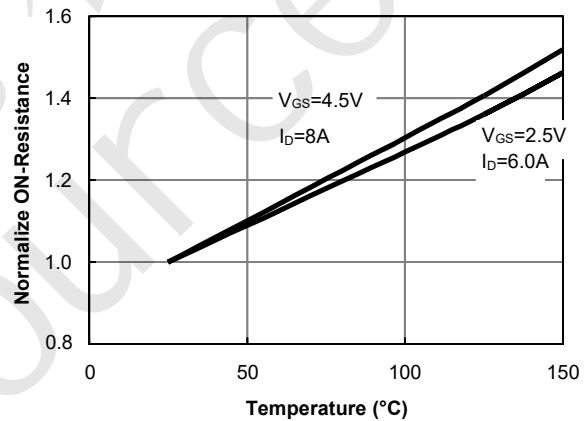

Figure 4: On-Resistance vs. Junction Temperature

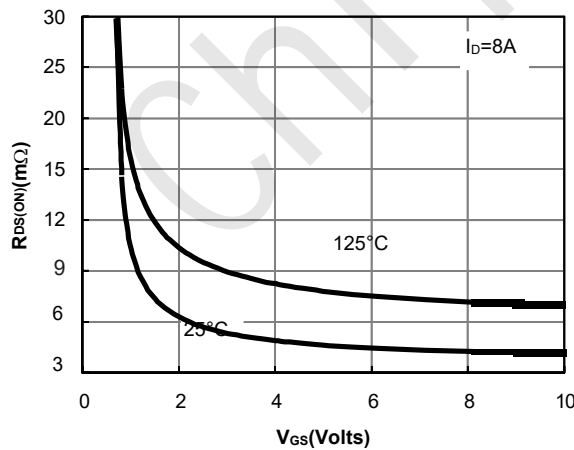

Figure 5: On-Resistance vs. Gate-Source Voltage

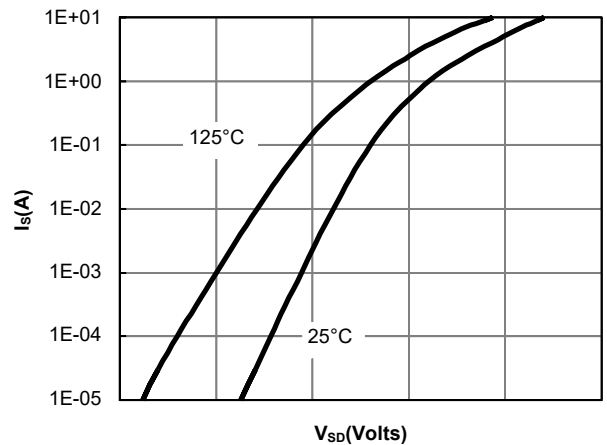

Figure 6: Body-Diode Characteristics



CST3330M TYPICAL ELECTRICAL AND THERMAL CHARACTERISTIC

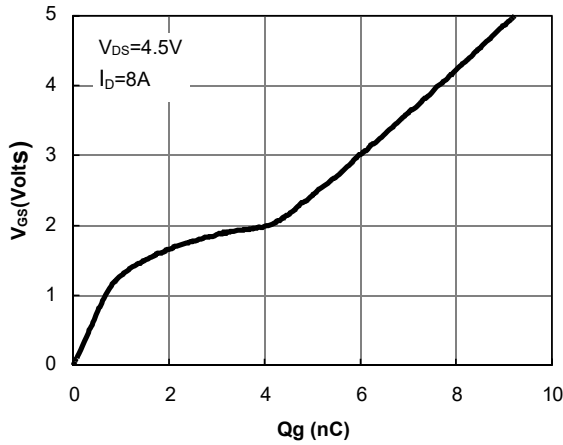

Figure 7: Gate-Charge Characteristics

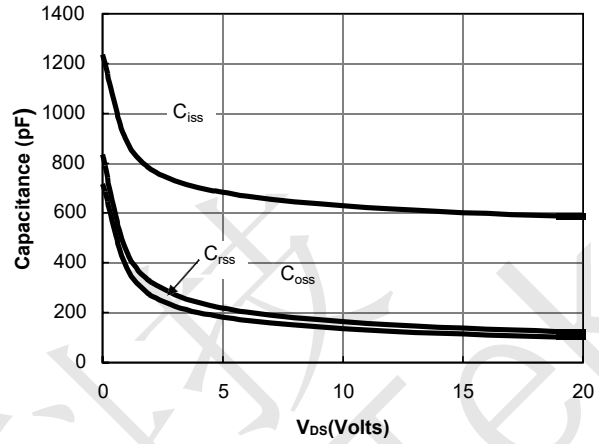

Figure 8: Capacitance Characteristics

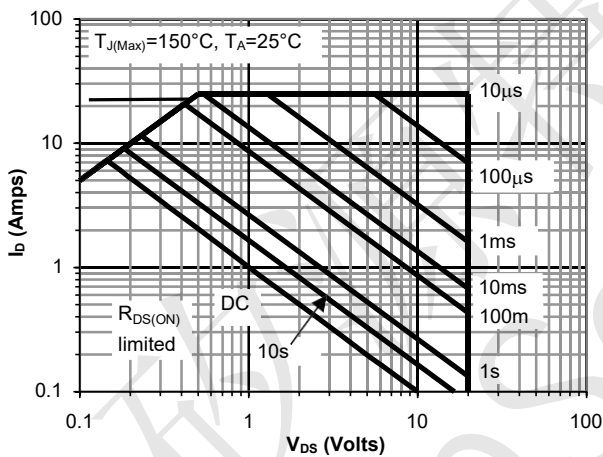

Figure 9: Maximum Forward Biased Safe Operating Area (Note E)

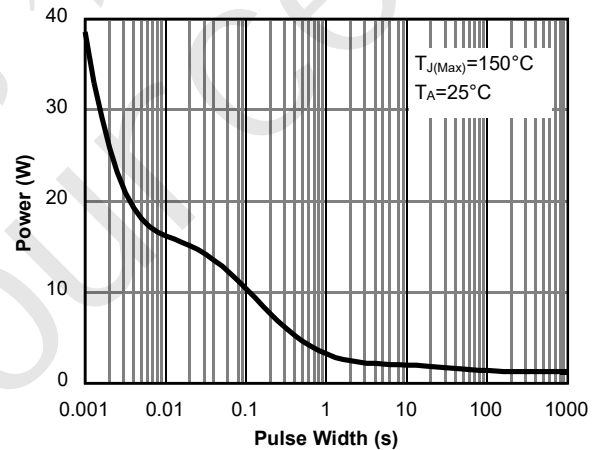

Figure 10: Single Pulse Power Rating Junction-to-Ambient

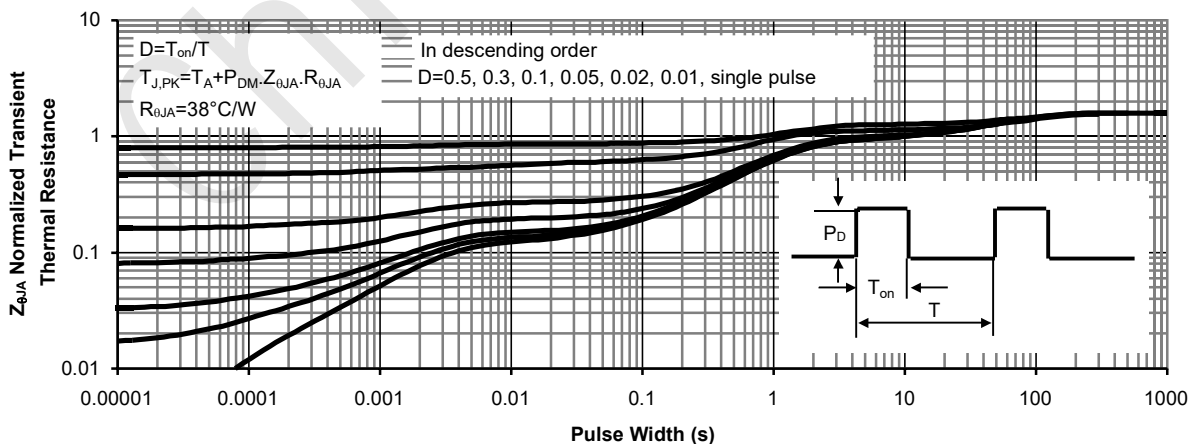
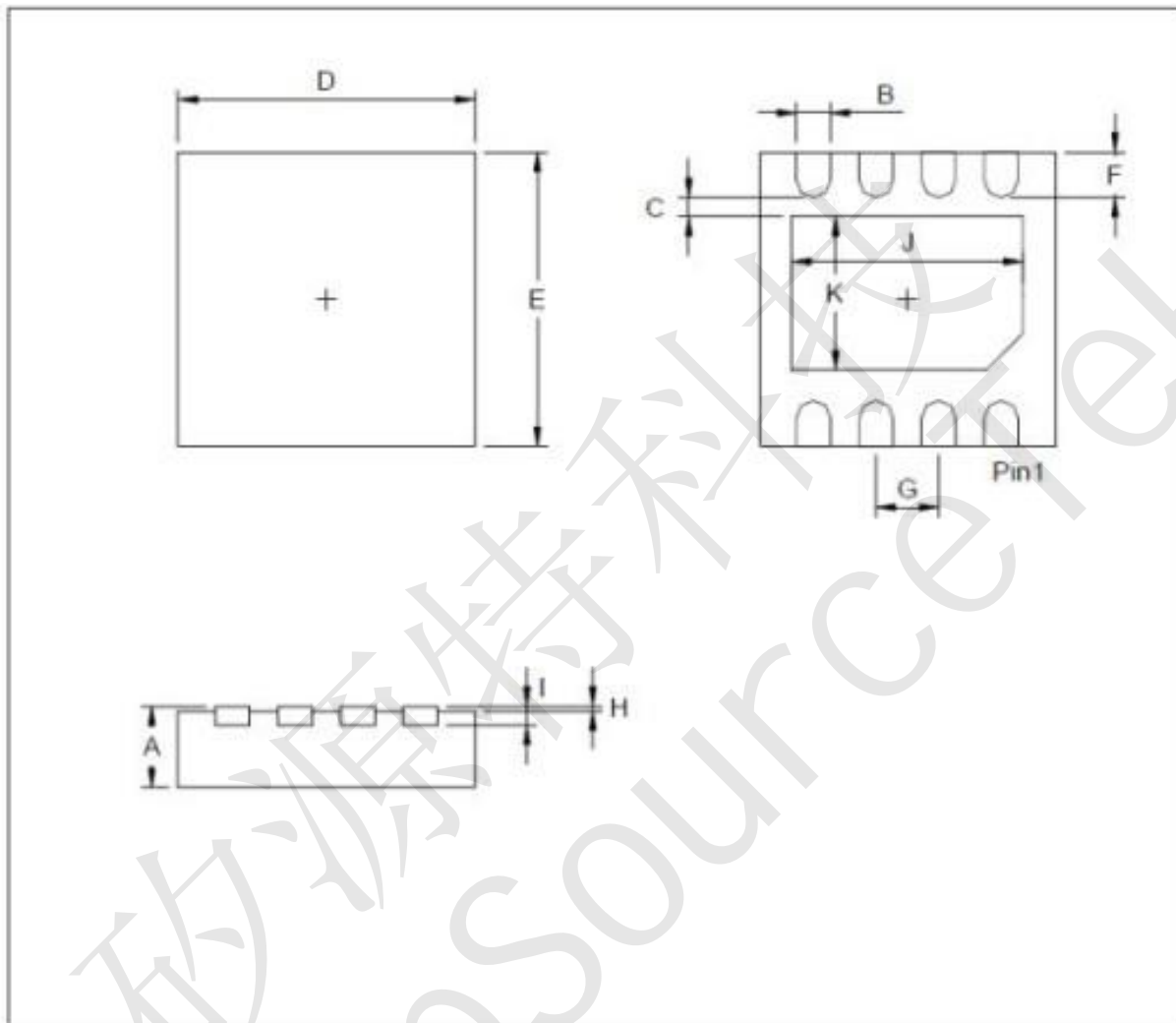

Figure 11: Normalized Maximum Transient Thermal Impedance



CST3330M DFN3030-8L Package Outline Data



Dimension	mm			Dimension	mm		
	Min.	Typ.	Max.		Min.	Typ.	Max.
A	0.7		0.8	I		0.203	
B	0.25		0.35	J	2.2		2.4
C	0.2			K	1.4		1.6
D	2.924		3.076				
E	2.924		3.076				
F	0.324		0.476				
G		0.65					
H	0		0.05				