



CST4002 Micro Power Unipolar Hall-effect Sensor Switch

■ CST4002 General Description

The CST4002 is Unipolar Hall effect sensor IC is fabricated from mixed signal CMOS technology. It is comprised of one Hall plate and a CMOS output drive, mainly designed for battery-operation. The total power consumption in normal operation is typically 5.6 μ W with a 2.8V power source. South/North poles of sufficient strength will turn the output on. The output will be turned off under no magnetic field.

The CST4002 is available in SIP-3L, SOT23-3L, SOT553, DFN1216-4L-EP Package. Operating temperature range of the CST4002 is from -40°C to 85°C.

■ CST4002 Features

- 2 μ A Micro power consumption ideal for battery-powered applications
- Input Voltage Range: 1.65V to 5.5V
- Very High Sensitivity Hall Sensor
- Chopper stabilized amplifier stage
- Good RF noise immunity
- CMOS Output
- SIP-3L, DFN1216-4L-EP, SOT23-3L, & SOT553 package

■ CST4002 Applications

- Solid State Switch
- Bluetooth Headset

■ CST4002 Pin Configuration

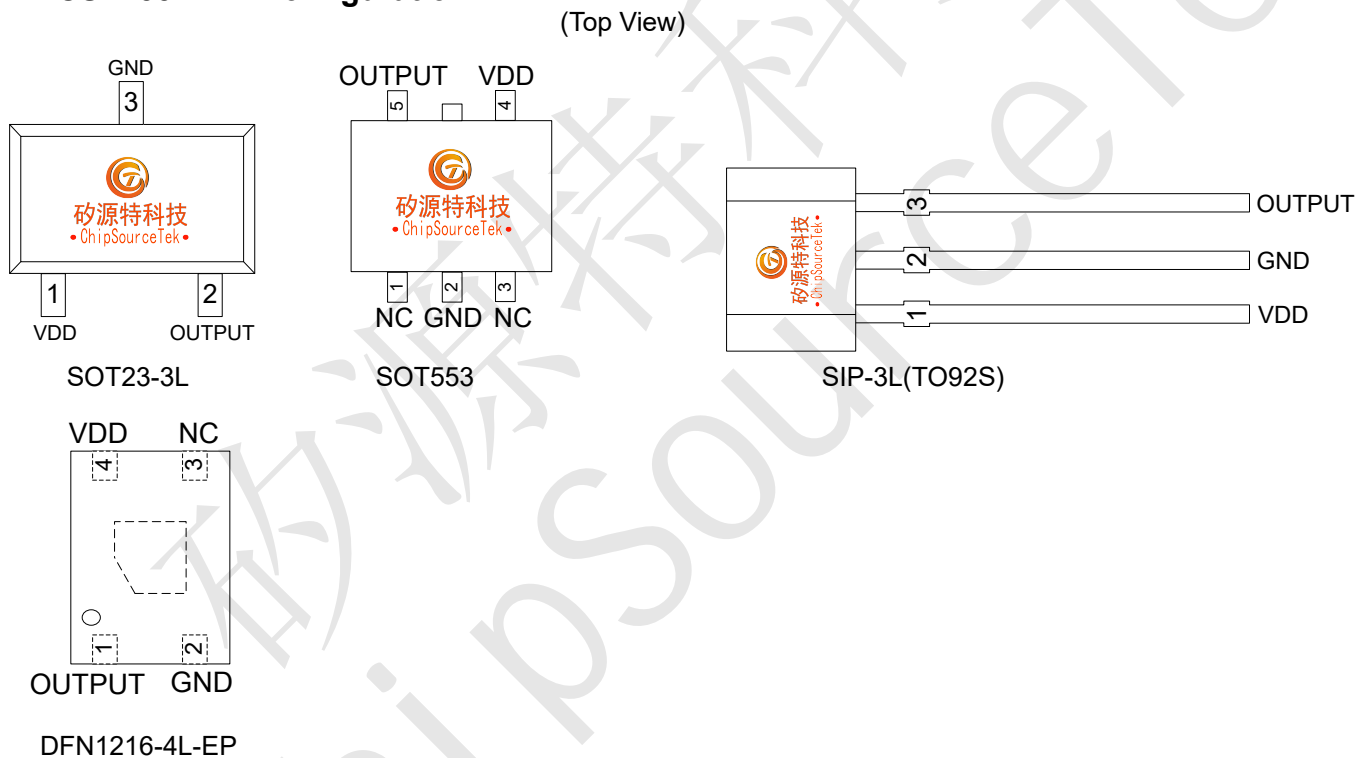

Pin Name	Pin Number				Description
	SOT23-3L	SOT553	SIP-3L	DFN1216-4L-EP	
VDD	1	4	1	4	IC Power Supply
OUTPUT	2	5	3	1	CST4002MD CST4002WAD CST4002STAD CST4002SEV4AD It is low state during the S Pole magnetic field CST4002NMD CST4002NWAD CST4002NSTAD CST4002NEV4AD It is low state during the N Pole magnetic field
GND	3	2	2	2	IC Ground
NC	-	1, 3	-	3	NC Pin



CST4002 Micro Power Unipolar Hall-effect Sensor Switch

■ CST4002 Ordering Information

Part Number	Package Type	Packing Qty	B _{OP} (Gauss)	B _{RP} (Gauss)	Temperature	Eco Plan	Lead
CST4002MD	SIP-3L	1000pcs/Bag	40(Typ.)	30(Typ.)	-40~ +85°C	ROHS	Cu
CST4002NMD	SIP-3L	1000pcs/Bag	-40(Typ.)	30(Typ.)	-40~ +85°C	ROHS	Cu
CST4002WAD	SOT23-3L	3000pcs/Reel	40(Typ.)	30(Typ.)	-40~ +85°C	ROHS	Cu
CST4002NWAD	SOT23-3L	3000pcs/Reel	-40(Typ.)	30(Typ.)	-40~ +85°C	ROHS	Cu
CST4002STAD	SOT553	3000pcs/Reel	40(Typ.)	30(Typ.)	-40~ +85°C	ROHS	Cu
CST4002NSTAD	SOT553	3000pcs/Reel	-40(Typ.)	30(Typ.)	-40~ +85°C	ROHS	Cu
CST4002SEV4AD	DFN1216-4L-EP	3000pcs/Reel	40(Typ.)	30(Typ.)	-40~ +85°C	ROHS	Cu
CST4002NEV4AD	DFN1216-4L-EP	3000pcs/Reel	-40(Typ.)	30(Typ.)	-40~ +85°C	ROHS	Cu

■ CST4002 Application Circuit

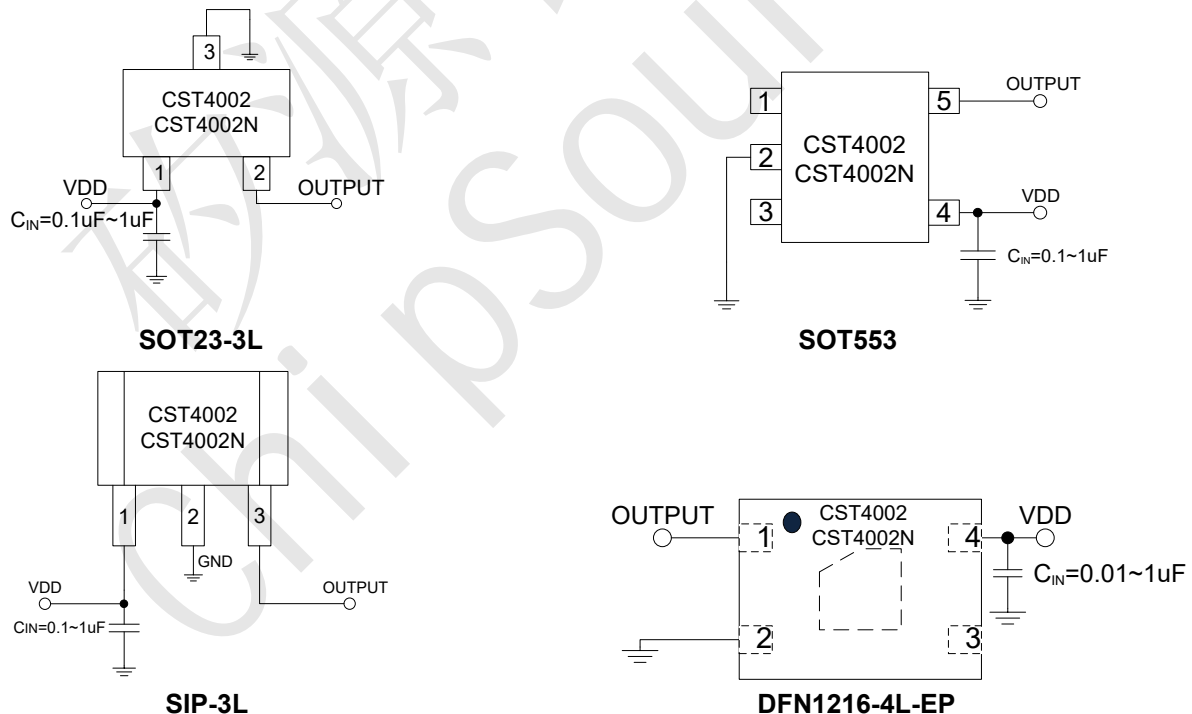

Figure 1, Application circuit

Note: C_{IN} is for power stabilization and to strengthen the noise immunity, the recommended capacitance is 0.1~1uF.



CST4002 Micro Power Unipolar Hall-effect Sensor Switch

■ CST4002 Block Diagram

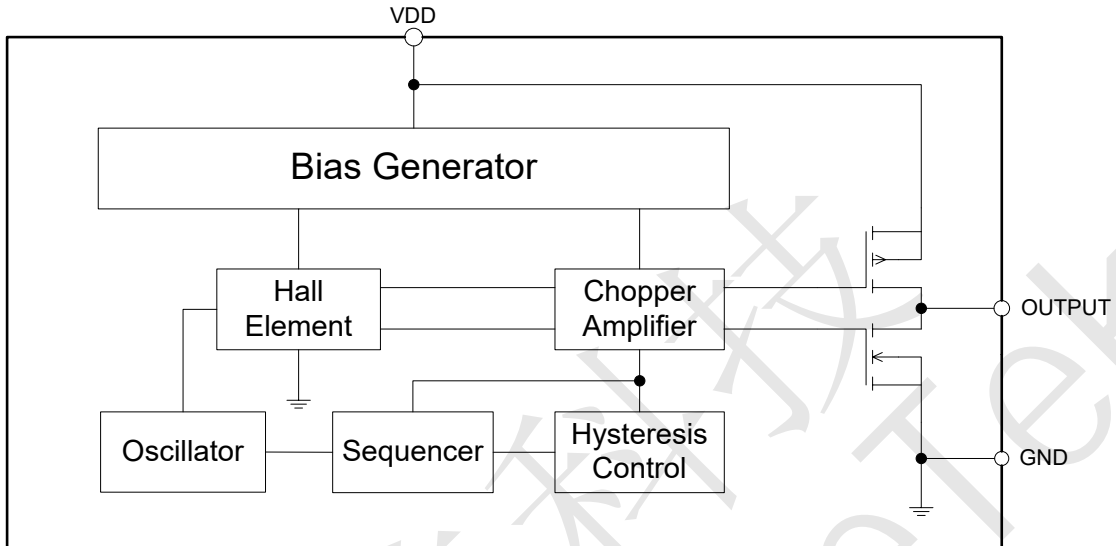

Figure 2, Block Diagram Of CST4002



CST4002 Micro Power Unipolar Hall-effect Sensor Switch

■ CST4002 Absolute Maximum Ratings (T_A=25°C unless otherwise noted)

Parameter	Symbol	Rating	Unit
VDD to GND	V _{DD}	-0.3 to +6	V
Magnetic Flux Density	B	Unlimited	
Storage Temperature Range	T _S	-55 to +150	°C
Operating Junction Temperature Range	T _J	-40 to +150	°C
Maximum Power Dissipation	SIP-3L	300	mW
	DFN1216-4L-EP		
	SOT23-3L	230	
	SOT553		
Maximum Soldering Temperature (at leads, 10 sec)	T _{LEAD}	260	°C

■ CST4002 Recommended Operating Conditions (T_A=25°C unless otherwise noted)

Parameter	Symbol	Conditions	Rating	Unit
Supply Voltage	V _{DD}	Operating	1.65 ~ 5.5	V
Operating Temperature Range	T _A	Operating	-40 ~ +85	°C

■ CST4002 Electrical Characteristics (Unless otherwise noted, typical values are at T_A=25°C, V_{DD}=2.8V)

Symbol	Parameter	Conditions	Min.	Typ.	Max.	Unit
V _{OH}	Output Off Voltage (High side)	I _{OUT} =+1mA	V _{DD} -0.3	V _{DD} -0.02	V _{DD}	V
V _{OL}	Output On Voltage (Low side)	I _{OUT} =-1mA	-	0.01	+0.3	V
I _{OFF}	Output Leakage Current	V _{OUT} =5V, Output off	-	<0.1	1	μA
I _{DD} (EN)	Supply Current	Chip enable, T _A =25°C, V _{DD} =2.8V	-	0.8	1.5	mA
I _{DD} (EN)		Chip enable, T _A =-40~85°C, V _{DD} =1.65~5.5V	-	1.1	2.6	mA
I _{DD} (DIS)		Chip disable, T _A =25°C, V _{DD} =2.8V	-	1.0	2.2	μA
I _{DD} (DIS)		Chip disable, T _A =-40~85°C, V _{DD} =1.65~5.5V	-	1.9	4	μA
I _{DD} (AVG)		Average supply current, T _A =25°C, V _{DD} =2.8V	-	2.0	4	μA
I _{DD} (AVG)		Average supply current, T _A =-40~+85°C, V _{DD} =1.65~5.5V	-	3.7	8	μA
T _{awake}		Awake Time	-	-	70	120
T _{period}	Period	-	-	42	80	ms
D.C.	Duty Cycle	-	-	0.16	-	%



CST4002 Micro Power Unipolar Hall-effect Sensor Switch

■ CST4002 Magnetic Characteristics

(Unless otherwise noted, typical values are at $T_A=25^\circ\text{C}$, $V_{DD}=2.8\text{V}$)

CST4002MD、CST4002WAD、CST4002STAD、CST4002SEV4AD					
Parameter	Symbol	Min.	Typ.	Max.	Unit
South Pole Operate Point	BOPS	20	40	58	Gauss
South Pole Release Point	BRPS	10	30	48	
Hysteresis	BHY (BOPS-BRPS)	-	10	-	

CST4002NMD、CST4002NWAD、CST4002NSTAD、CST4002NEV4AD					
Parameter	Symbol	Min.	Typ.	Max.	Unit
North Pole Operate Point	BOPN	-58	-40	-20	Gauss
North Pole Release Point	BRPN	-48	-30	-10	
Hysteresis	BHY (BOPN-BRPN)	-	10	-	

■ CST4002 Output Vs. Magnetic Pole

Part Number	Magnetic Pole	Test Conditions	Output Status
CST4002MD、CST4002WAD CST4002STAD、CST4002SEV4AD	South Pole	$B > B_{OPS}$	Low
CST4002MD、CST4002WAD CST4002STAD、CST4002SEV4AD	South Pole	$B < B_{RPS}$	High
CST4002NMD、CST4002NWAD CST4002NSTAD、 CST4002NEV4AD	North pole	$B < B_{OPN}$	Low
CST4002NMD、CST4002NWAD CST4002NSTAD、 CST4002NEV4AD	North pole	$B > B_{RPN}$	High

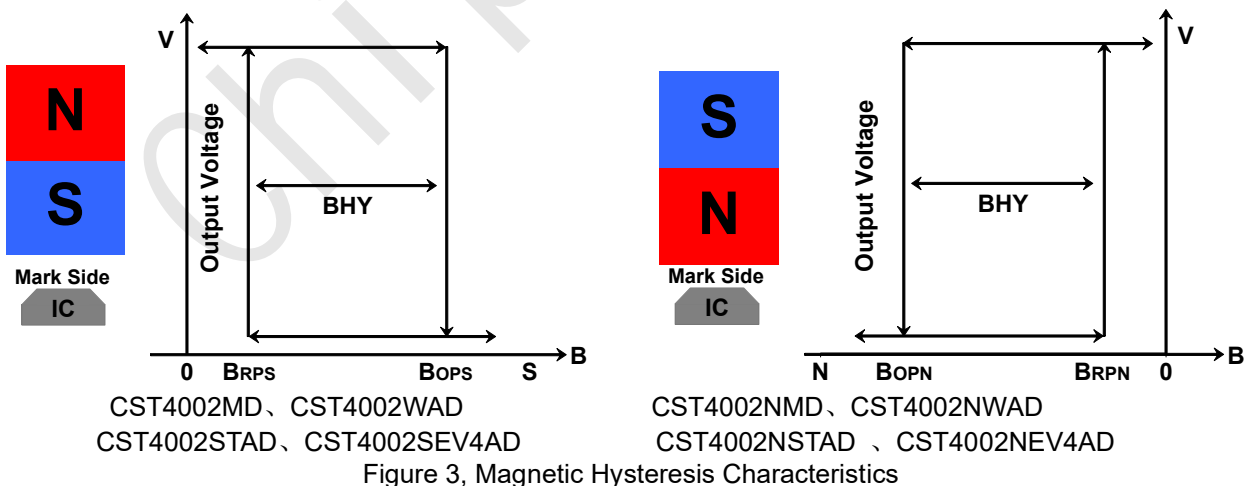



CST4002 Micro Power Unipolar Hall-effect Sensor Switch

■ CST4002 Hall Sensor Location

(Top View)

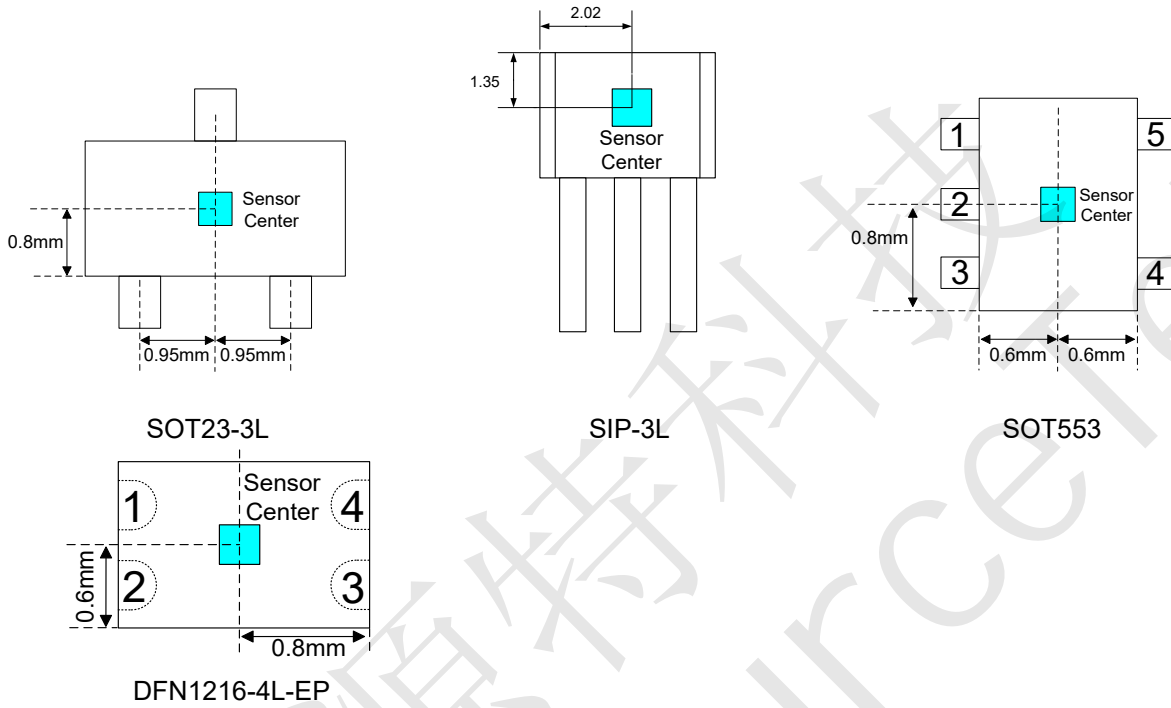
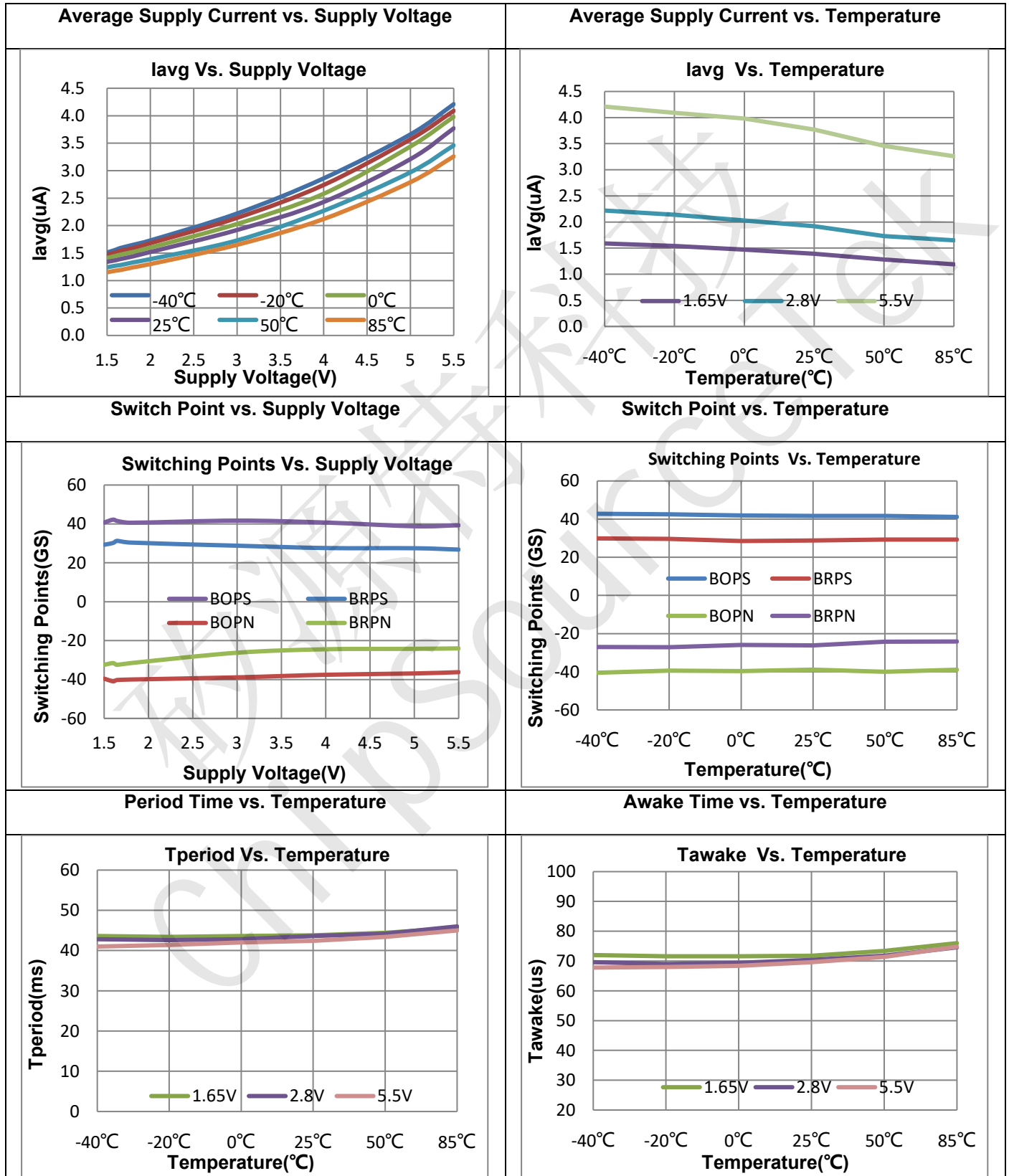

Figure4, Hall Sensor Location



CST4002 Micro Power Unipolar Hall-effect Sensor Switch

■ **Typical Characteristics—CST4002** (Unless otherwise noted, $V_{DD} = 2.8V$, $T_A = 25^\circ C$)





CST4002 Micro Power Unipolar Hall-effect Sensor Switch

■ CST4002 Functional Description

Low Average Power

Internal timing circuitry activates the sensor for 70 μ s and deactivates it for the remainder of the period(42ms). A short "awake" time allows for stabilization prior to the sensor sampling and data latching on the falling edge of the timing pulse. The output during the "sleep" time is latched in the last sampled state. The supply current is not affected by the output state.

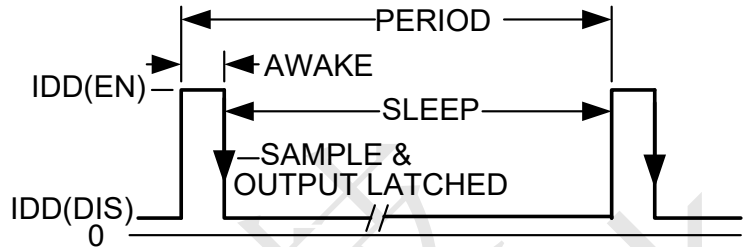

Chopper-Stabilized Technique

The Hall element can be considered as a resistor array similar to a Wheatstone bridge. A large portion of the offset is a result of the mismatching of these resistors. These devices use a proprietary dynamic offset cancellation technique, with an internal high-frequency clock to reduce the residual offset voltage of the Hall element that is normally caused by device over-molding, temperature dependencies, and thermal stress. The chopper-stabilizing technique cancels the mismatching of the resistor circuit by changing the direction of the current flowing through the Hall plate using CMOS switches and Hall voltage measurement taps, while maintains the Hall voltage signal that is induced by the external magnetic flux. The signal is then captured by a sample-and-hold circuit and further processed using low-offset bipolar circuitry. This technique produces devices that have an extremely stable quiescent Hall output voltage, are immune to thermal stress, and have precise recoverability after temperature cycling. A relatively high sampling frequency is used for faster signal processing capability can be processed.

Magnetic Field Detection Mechanism

The Hall IC cannot detect magnetic fields that run horizontal to the package top layer. Be certain to configure the Hall IC so that the magnetic field is perpendicular to the top layer.

Operation

The output of this device switches low (turns on) when a magnetic field perpendicular to the Hall sensor exceeds the operate point B_{OPS} (or is less than B_{OPN}). After turn-on, the output is capable of sinking up to 1mA and the output voltage is $V_{OUT}(ON)$. When the magnetic field is reduced below the release point B_{RPS} (or increased above B_{RPN}), the device output switches high (turns off). The difference between the magnetic operates and release points are the hysteresis (B_{hys}) of the device. This built-in hysteresis allows clean switching of the output even in the presence of external mechanical vibration and electrical noise.

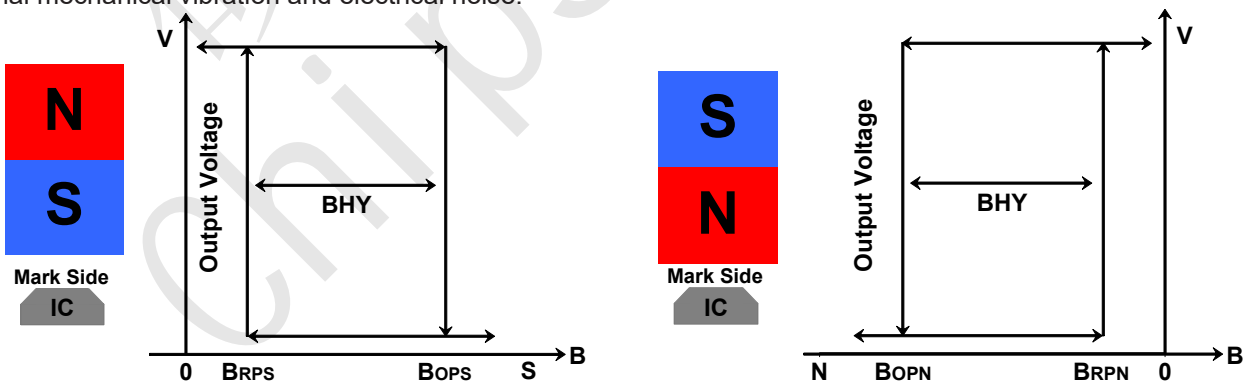



CST4002 Micro Power Unipolar Hall-effect Sensor Switch

■ CST4002 Marking Information

(1) SOT23-3L

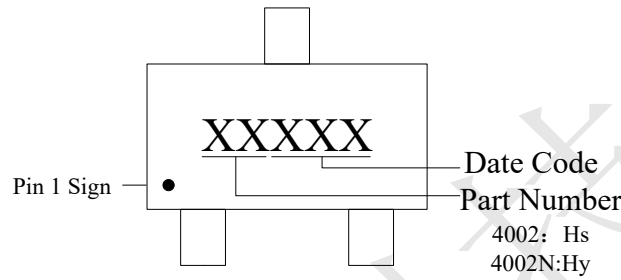

(2) SIP-3L

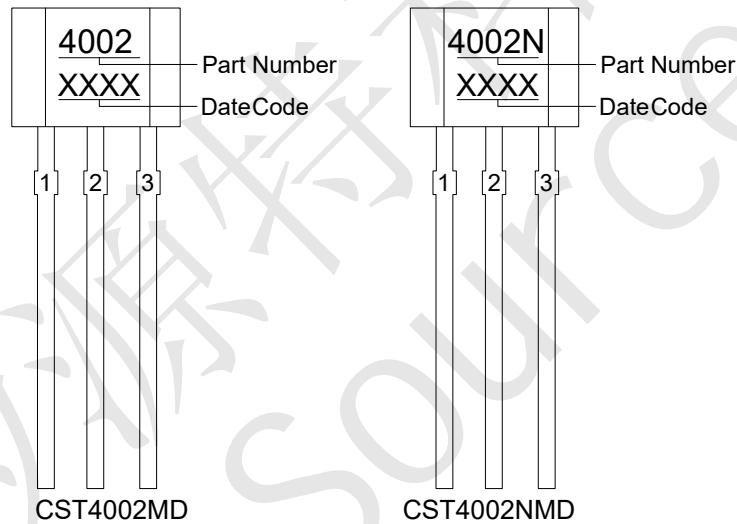

(3) SOT553

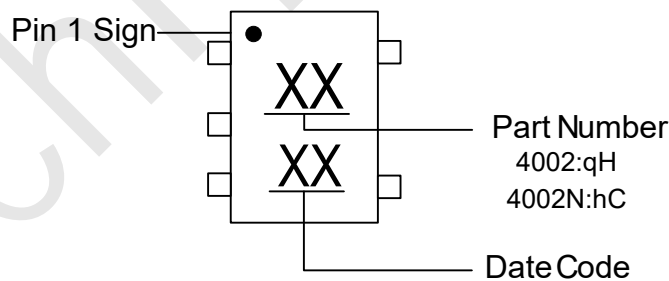



CST4002 Micro Power Unipolar Hall-effect Sensor Switch

(4) DNF1216-4L-EP

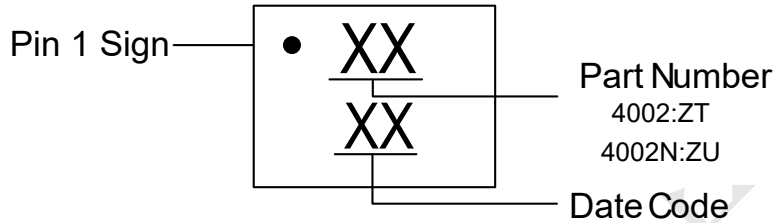

■ CST4002 Package Information

1) SIP-3L

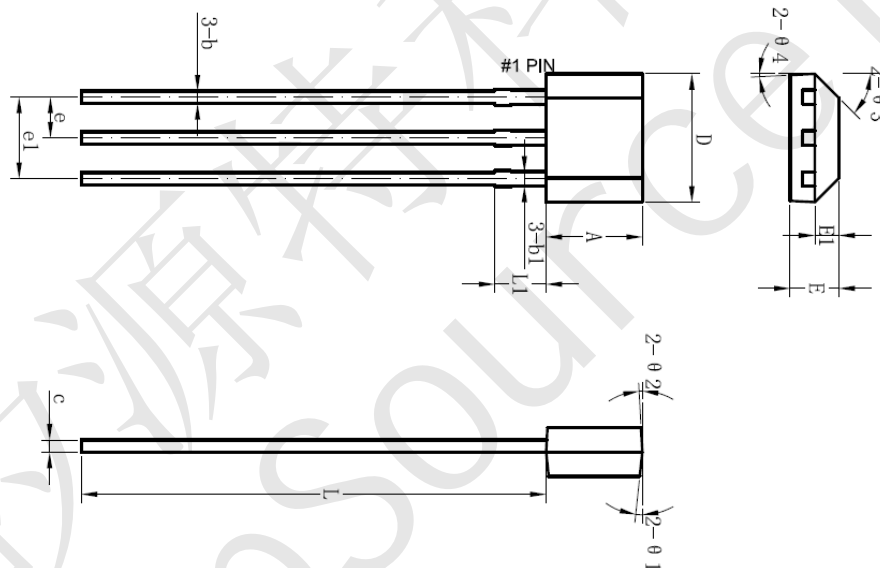

Symbol	Dimensions In Millimeters			Dimensions In Inches		
	Min.	Typ.	Max.	Min.	Typ.	Max.
A	2.90	3.00	3.10	0.11	0.12	0.12
b	0.35	0.39	0.56	0.01	0.02	0.02
b1		0.44			0.02	
c	0.36	0.38	0.51	0.01	0.01	0.02
D	3.9	4.0	4.2	0.15	0.16	0.16
E	1.42	1.52	1.62	0.06	0.06	0.06
E1		0.75			0.03	
e		1.27			0.05	
e1		2.54			0.10	
L	13.50	14.50	15.50	0.53	0.57	0.61
L1		1.60			0.06	
θ1		6°			0.24°	
θ2		3°			0.12°	
θ3		45°			1.77°	
θ4		3°			0.12°	



CST4002 Micro Power Unipolar Hall-effect Sensor Switch

■ CST4002 Package Information

2) SOT23-3L

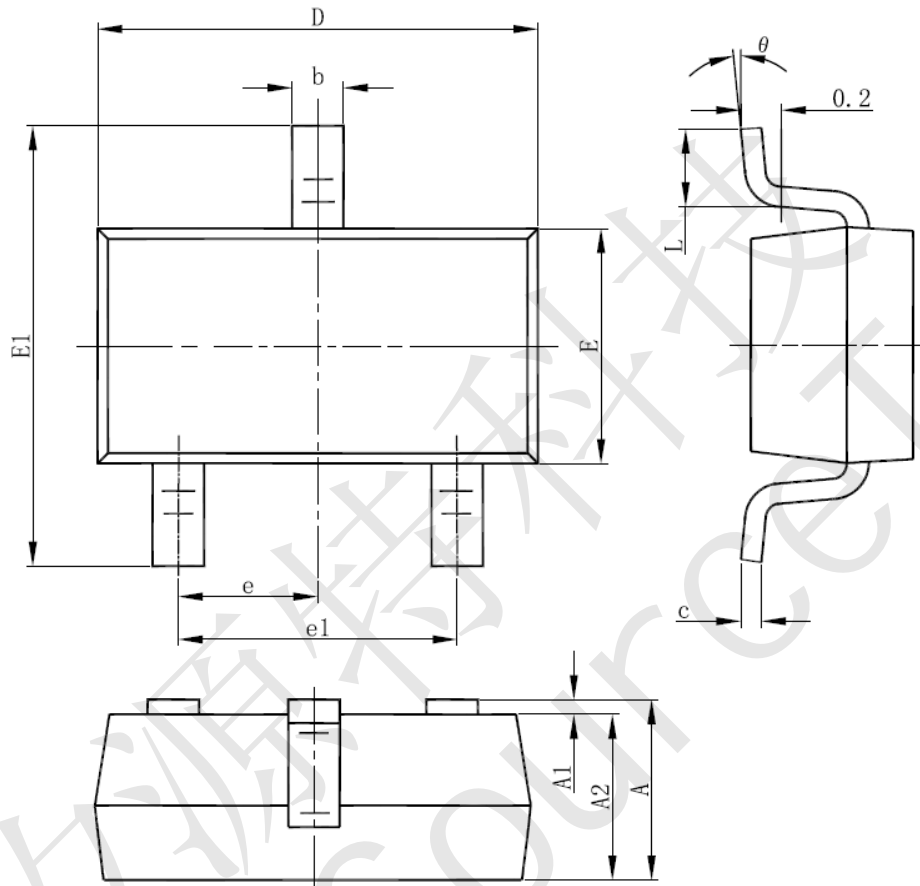

Symbol	Dimensions In Millimeters			Dimensions In Inches		
	Min.	Typ.	Max.	Min.	Typ.	Max.
A	1.050	1.15	1.250	0.041	0.045	0.049
A1	0.000	0.050	0.100	0.000	0.002	0.004
A2	1.050	1.100	1.150	0.041	0.043	0.045
b	0.300	0.400	0.500	0.012	0.016	0.020
c	0.100	0.150	0.200	0.004	0.006	0.008
D	2.820	2.920	3.020	0.111	0.115	0.119
E	1.500	1.600	1.700	0.059	0.063	0.067
E1	2.650	2.800	2.950	0.104	0.110	0.116
e1	1.800	1.900	2.000	0.071	0.075	0.079
e	0.950 REF			0.037 REF		
L	0.300	0.450	0.600	0.012	0.018	0.024
θ	0°	4°	8°	0°	4°	8°



CST4002 Micro Power Unipolar Hall-effect Sensor Switch

■ CST4002 Package Information

3) SOT553

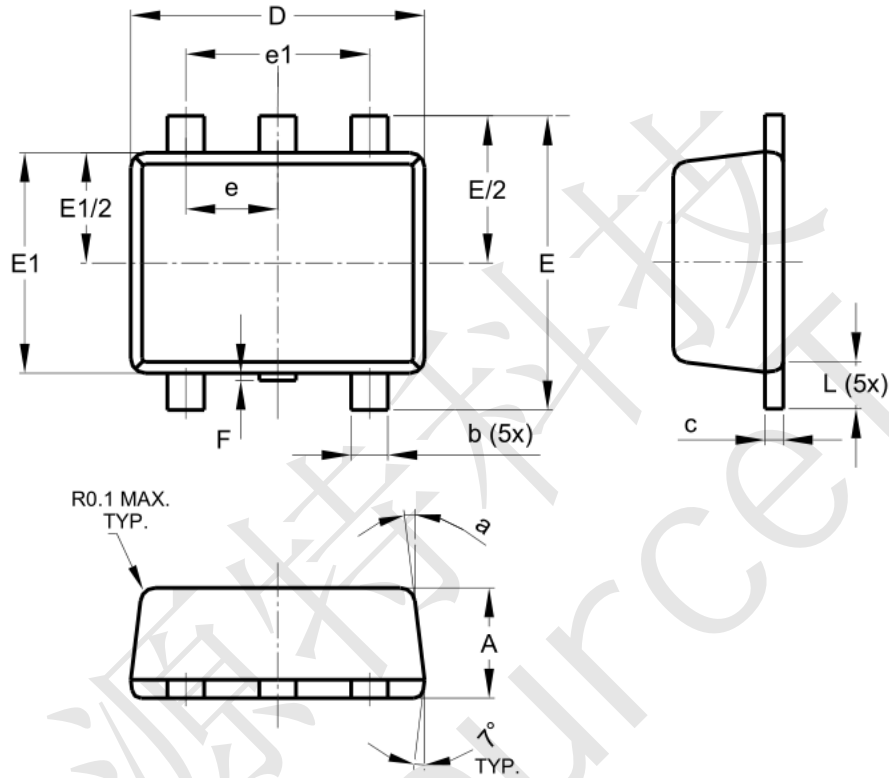

Symbol	Dimensions In Millimeters			Dimensions In Inches		
	Min.	Typ.	Max.	Min.	Typ.	Max.
A	0.55	0.60	0.62	0.22	0.24	0.24
b	0.15	0.20	0.30	0.06	0.08	0.12
c	0.10	0.20	0.18	0.04	0.08	0.07
D	1.50	1.60	1.70	0.59	0.63	0.67
E	1.55	1.60	1.70	0.61	0.63	0.67
E1	1.10	1.20	1.25	0.43	0.47	0.49
e	0.50 (BSC)			0.20 (BSC)		
e1	1.00 (BSC)			0.39 (BSC)		
F	0.00	-	0.10	0.00	-	0.04
L	0.10	0.20	0.30	0.04	0.08	0.12
a	6°	7°	8°	-	-	-



CST4002 Micro Power Unipolar Hall-effect Sensor Switch

■ CST4002 Package Information

4) DFN1216-4L-EP

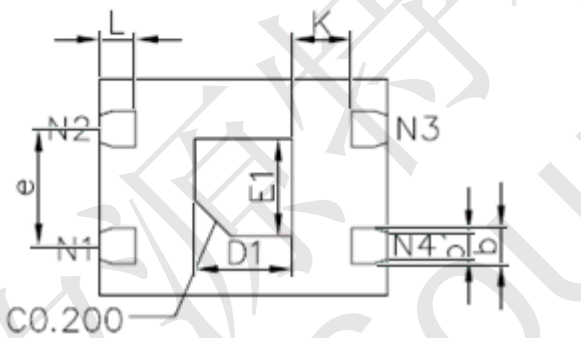
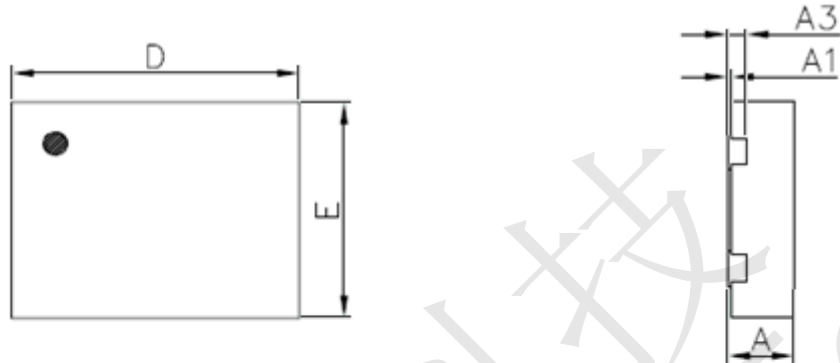

Symbol	Dimensions In Millimeters			Dimensions In Inches		
	Min.	Typ.	Max.	Min.	Typ.	Max.
A	0.320	0.370	0.400	0.013	0.145	0.016
A1	0.000	-	0.050	0.000	-	0.002
A3	0.102 (REF)			0.004 (REF)		
D	1.500	1.600	1.700	0.059	0.63	0.067
E	1.100	1.200	1.300	0.043	0.47	0.051
D1	0.440	0.540	0.640	0.017	0.021	0.025
E1	0.440	0.540	0.640	0.017	0.021	0.025
k	0.330 (REF)			0.013 (REF)		
b	0.150	0.200	0.250	0.006	0.008	0.010
b1	0.150 (REF)			0.006 (REF)		
e	0.650 (BSC)			0.026 (BSC)		
L	0.150	0.200	0.250	0.006	0.008	0.010



CST4002 Micro Power Unipolar Hall-effect Sensor Switch

■ CST4002 Packing Information

1) SIP-3L

1. Packing Type: Bag
2. Packing minimum: 1000pcs/Bag

2) SOT23-3L/SOT553/ DFN1216-4L-EP

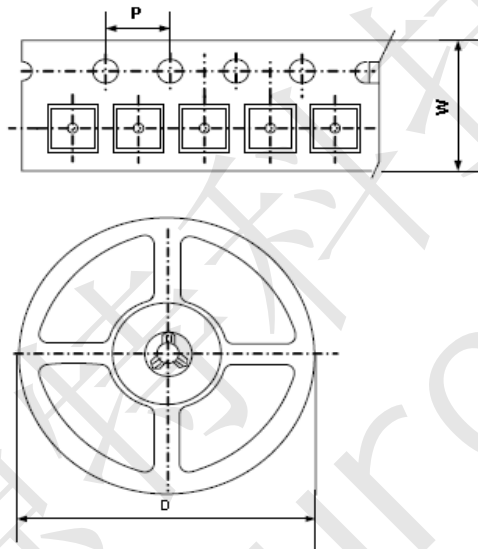

QUADRANT ASSIGNMENTS FOR PIN 1 ORIENTATION IN TAPE

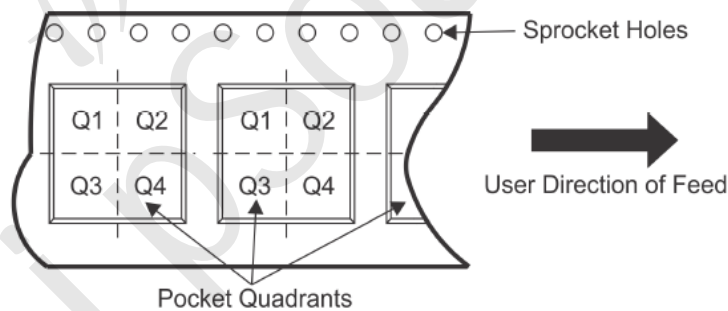

Package Type	Carrier Width (W)	Pitch (P)	Reel Size(D)	Packing Minimum	PIN1 Quadrant
SOT23-3L SOT553	8.0±0.1 mm	4.0±0.1 mm	180±1 mm	3000pcs	/
DFN1216-4L-EP	8.0±0.1 mm	4.0±0.1 mm	180±1 mm	3000pcs	Q2

Note: Carrier Tape Dimension, Reel Size and Packing Minimum



CST4002 Micro Power Unipolar Hall-effect Sensor Switch

IMPORTANT NOTICE

The Company reserve the right to make corrections, modifications, enhancements, improvements, and other changes to its products. Customers should obtain the latest relevant information before placing orders and should verify that such information is current and complete. These separate provisions won't be provided.

矽源特科技
ChipSourceTek