



- ★ Super Low Gate Charge
- ★ 100% EAS Guaranteed
- ★ Green Device Available
- ★ Excellent CdV/dt effect decline
- ★ Advanced high cell density Trench technology

CST65N06 Product Summary



BVDSS	RDS(on)	ID
60V	6.8mΩ	65A

CST65N06 Description

The CST65N06 is the high cell density trenched N-ch MOSFETs, which provide excellent RDS(on) and gate charge for most of the synchronous buck converter applications.

The CST65N06 meet the RoHS and Green Product requirement 100% EAS guaranteed with full function reliability approved.

CST65N06 TO252 Pin Configuration

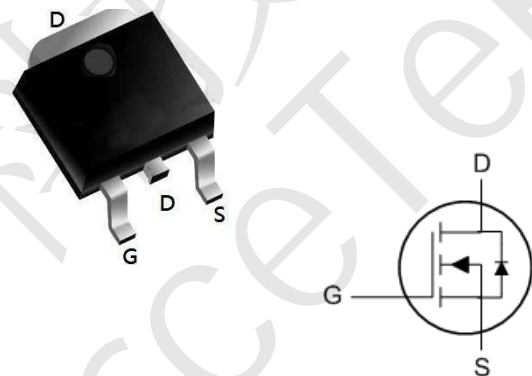

CST65N06 Absolute Maximum Ratings (TA=25°C)

Symbol	Parameter	Value	Unit
V _{DS}	Drain-Source Voltage (V _{GS} =0V)	60	V
V _{GS}	Gate-Source Voltage (V _{DS} =0V)	±20	V
I _{D(DC)}	Drain Current (DC) at T _c =25°C	65	A
I _{D(DC)}	Drain Current (DC) at T _c =100°C	45	A
I _{DM (pluse)}	Drain Current-Continuous@ Current-Pulsed (Note 1)	260	A
dv/dt	Peak Diode Recovery Voltage	8	V/ns
P _D	Maximum Power Dissipation(T _c =25°C)	75	W
	Derating Factor	0.5	W/°C
EAS	Single Pulse Avalanche Energy (Note 2)	300	mJ
T _J , T _{STG}	Operating Junction and Storage Temperature Range	-55 To 175	°C

Notes 1.Repetitive Rating: Pulse width limited by maximum junction temperature

2.EAS condition:T_J=25°C,V_{DD}=33V,V_G=10V



Thermal Characteristic

Symbol	Parameter	Value	Max	Unit
$R_{\theta JC}$	Thermal Resistance, Junction-to-Case	---	2.0	$^{\circ}C/W$

CST65N06 Electrical Characteristics (TA=25 $^{\circ}C$ unless otherwise noted)

Symbol	Parameter	Conditions	Min	Typ	Max	Unit
On/Off States						
BV_{DSS}	Drain-Source Breakdown Voltage	$V_{GS}=0V, I_D=250\mu A$	60	---	---	V
I_{DSS}	Zero Gate Voltage Drain Current(Tc=25 $^{\circ}C$)	$V_{DS}=64V, V_{GS}=0V$	---	---	1	μA
I_{DSS}	Zero Gate Voltage Drain Current(Tc=125 $^{\circ}C$)	$V_{DS}=64V, V_{GS}=0V$	---	---	10	μA
I_{GSS}	Gate-Body Leakage Current	$V_{GS}=\pm 20V, V_{DS}=0V$	---	---	± 100	nA
$V_{GS(th)}$	Gate Threshold Voltage	$V_{DS}=V_{GS}, I_D=250\mu A$	2	---	4	V
$R_{DS(ON)}$	Drain-Source On-State Resistance	$V_{GS}=10V, I_D=40A$	---	6.8	8.2	m Ω
Dynamic Characteristics						
g_{FS}	Forward Transconductance	$V_{DS}=10V, I_D=15A$	15	---	---	S
C_{iss}	Input Capacitance	$V_{DS}=25V, V_{GS}=0V,$ $f=1.0MHz$	---	2873	---	pF
C_{oss}	Output Capacitance		---	252	---	pF
C_{rss}	Reverse Transfer Capacitance		---	205	---	pF
Q_g	Total Gate Charge	$V_{DS}=50V, I_D=40A,$ $V_{GS}=10V$	---	56	---	nC
Q_{gs}	Gate-Source Charge		---	10	---	nC
Q_{gd}	Gate-Drain Charge		---	16	---	nC
Switching Times						
$t_{d(on)}$	Turn-on Delay Time	$V_{DD}=30V, I_D=2A, R_L=15\Omega$ $V_{GS}=10V, R_G=2.5\Omega$	---	14.5	---	nS
t_r	Turn-on Rise Time		---	24	---	nS
$t_{d(off)}$	Turn-Off Delay Time		---	45	---	nS
t_f	Turn-Off Fall Time		---	22	---	nS
Source-Drain Diode Characteristics						
I_{SD}	Source-Drain Current(Body Diode)		---	65	---	A
I_{SDM}	Pulsed Source-Drain Current(Body Diode)		---	260	---	A
V_{SD}	Forward On Voltage ^(Note 1)	$T_J=25^{\circ}C, I_{SD}=40A, V_{GS}=0V$	---	0.89	0.99	V
t_{rr}	Reverse Recovery Time ^(Note 1)	$T_J=25^{\circ}C, I_F=75A$ $di/dt=100A/\mu s$	---	22	---	nS
Q_{rr}	Reverse Recovery Charge ^(Note 1)		---	27	---	nC
t_{on}	Forward Turn-on Time	Intrinsic turn-on time is negligible(turn-on is dominated by L_S+L_D)				

Notes 1. Pulse Test: Pulse Width $\leq 300\mu s$, Duty Cycle $\leq 1.5\%$, $R_G=25\Omega$, Starting $T_J=25^{\circ}C$



CST65N06 N-Ch 60V Fast Switching MOSFETs

CST65N06 TYPICAL ELECTRICAL AND THERMAL CHARACTERISTICS (Curves)

Figure1. Output Characteristics

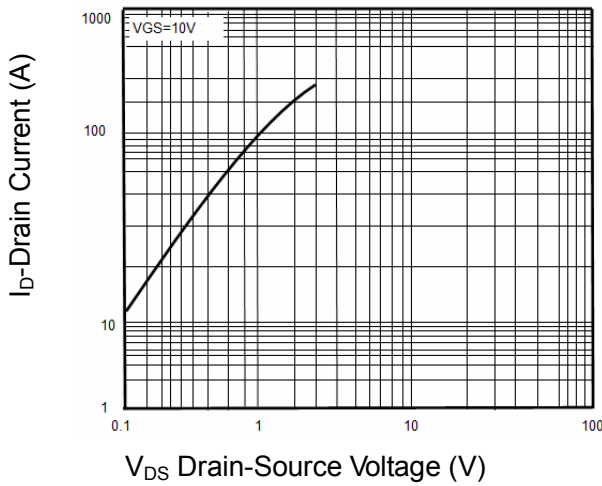

Figure2. Transfer Characteristics

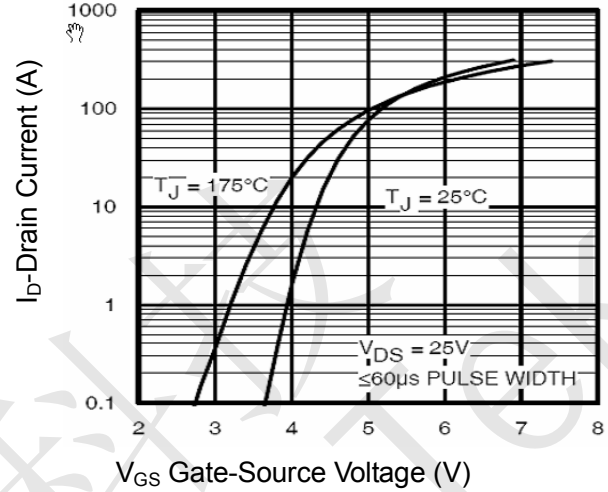

Figure3. BVDS vs Junction Temperature

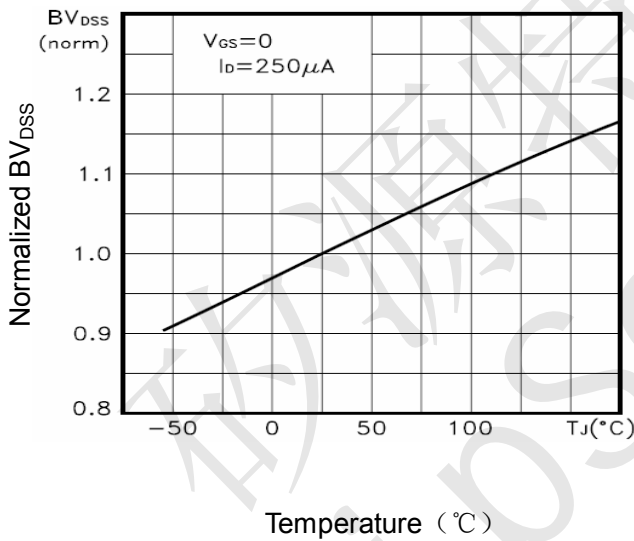

Figure4. ID vs Junction Temperature

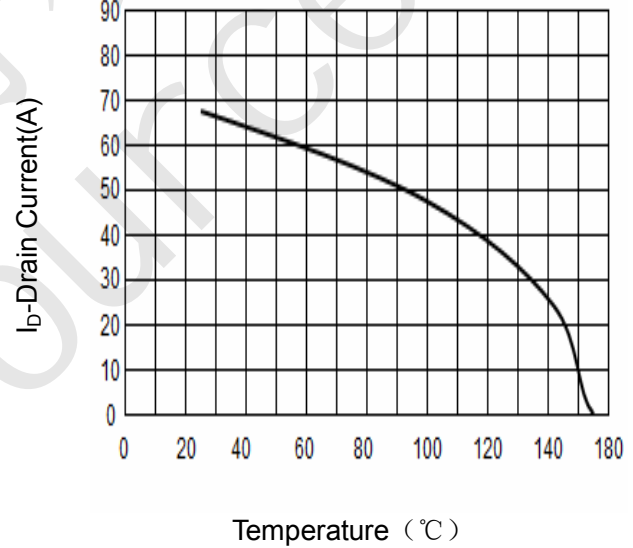

Figure5. VGS(th) vs Junction Temperature

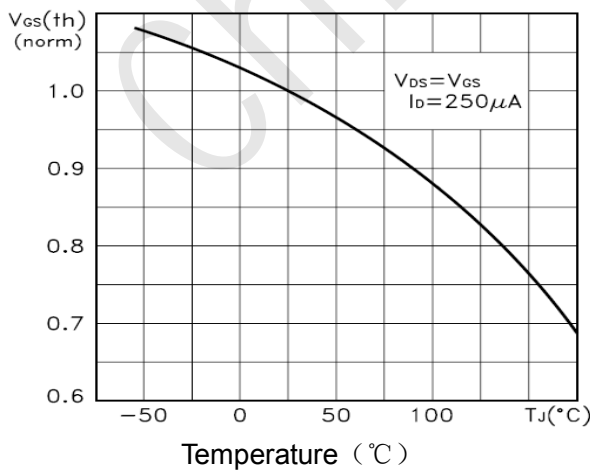

Figure6. Rds(on) Vs Junction Temperature

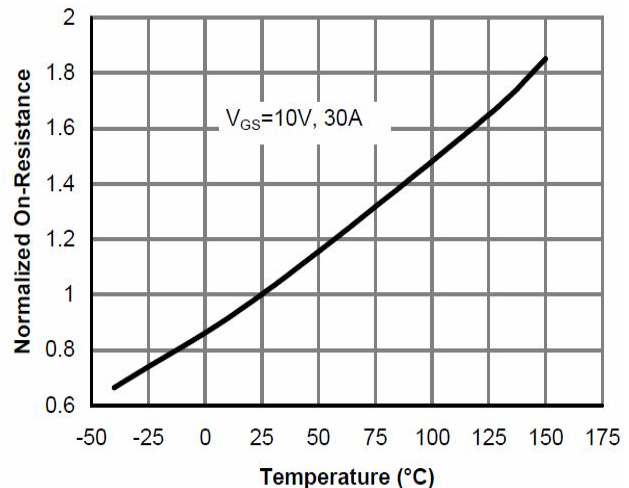



Figure7. Gate Charge

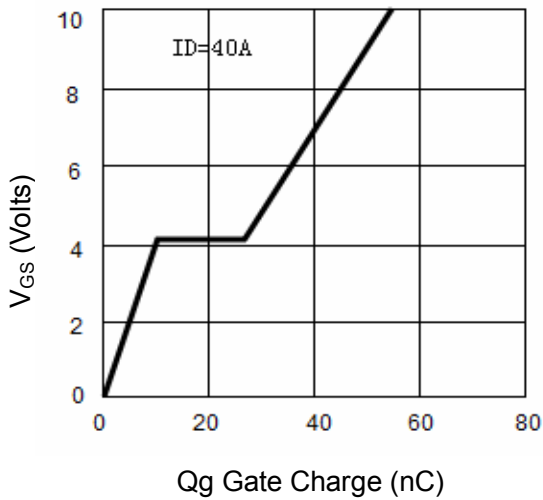

Figure8. Capacitance vs Vds

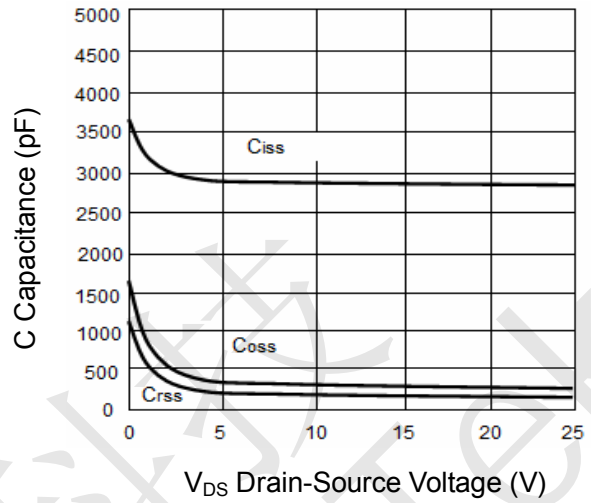

Figure9. Source- Drain Diode Forward

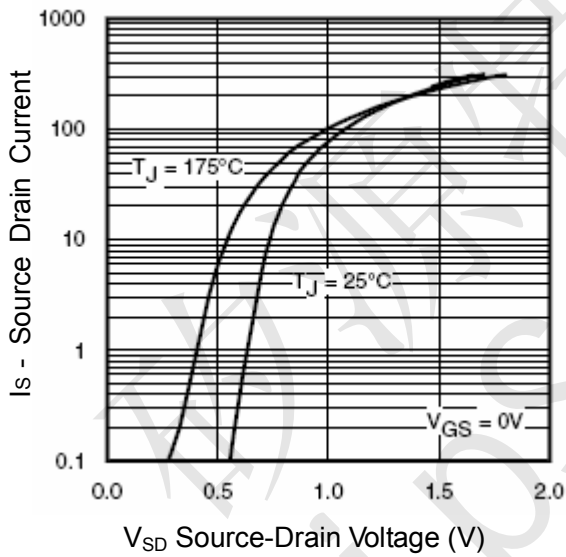

Figure10. Safe Operation Area

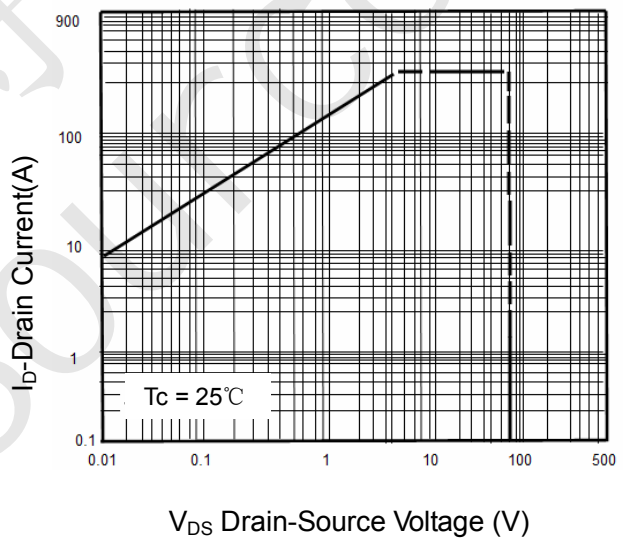
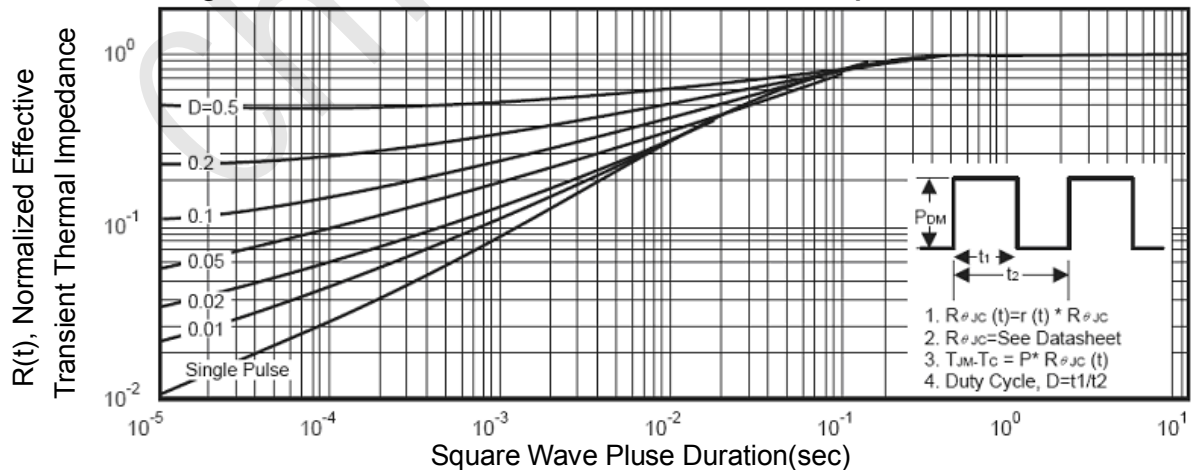

Figure11. Normalized Maximum Transient Thermal Impedance





CST65N06 Test Circuit

1) E_{AS} Test Circuits

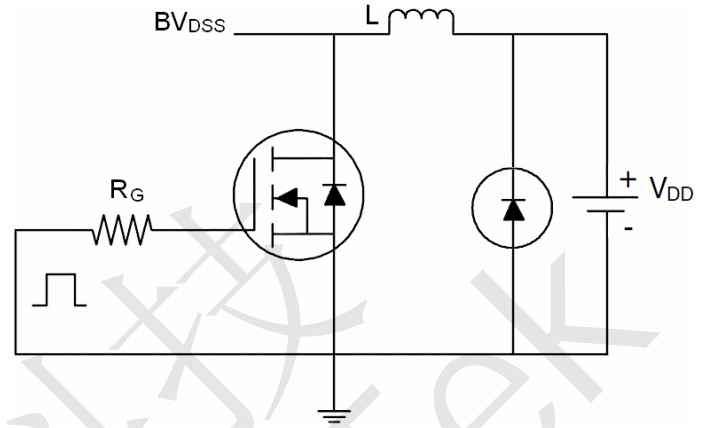
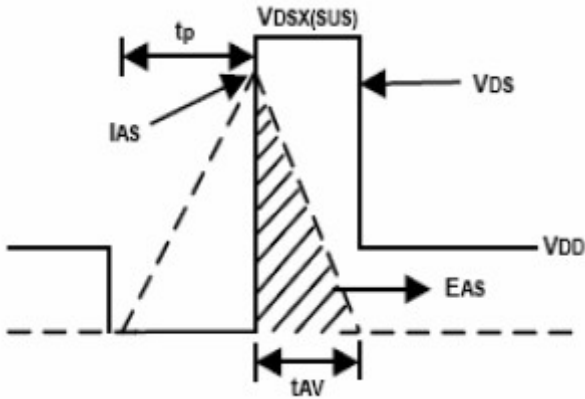

2) Gate Charge Test Circuit:

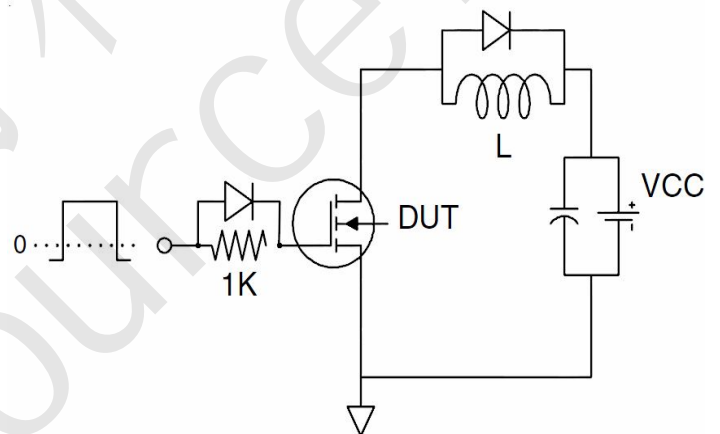
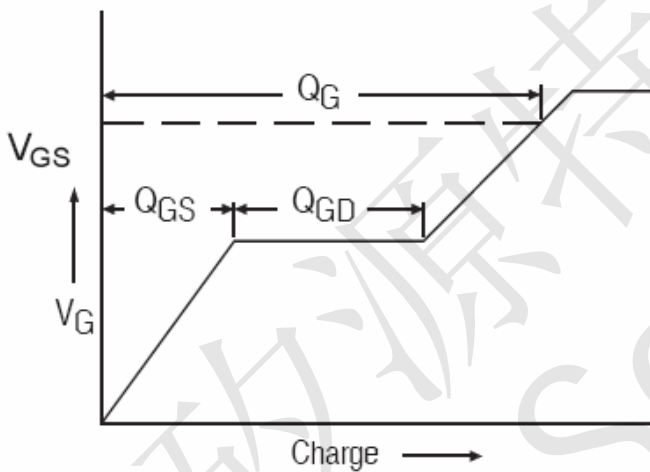

3) Switch Time Test Circuit:

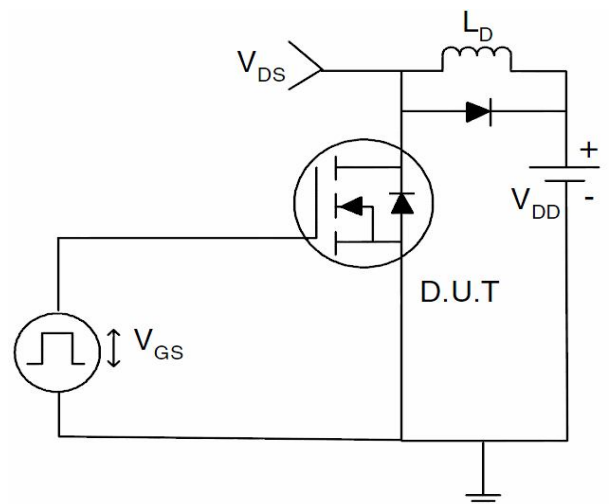
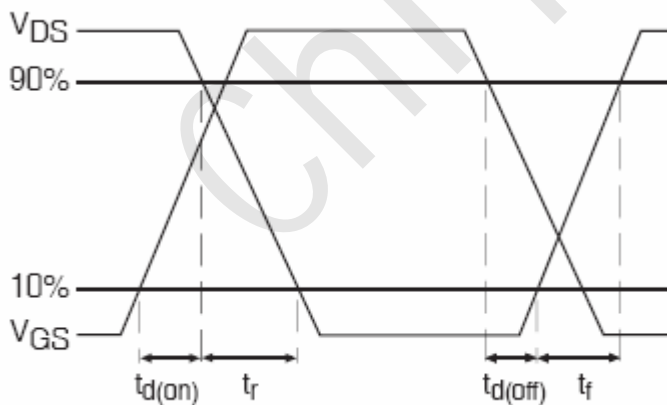



CST65N06 N-Ch 60V Fast Switching MOSFETs

CST65N06 Package Mechanical Data-TO-252-4R

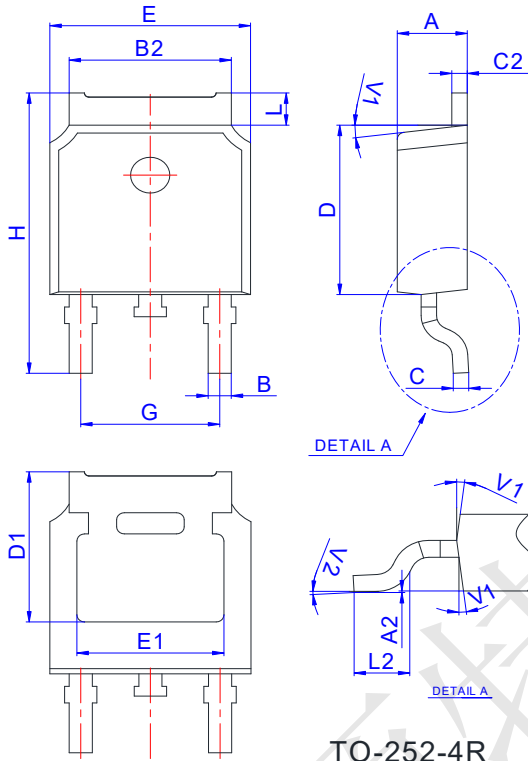

TO-252-4R

Ref.	Dimensions					
	Millimeters			Inches		
	Min.	Typ.	Max.	Min.	Typ.	Max.
A	2.10		2.50	0.083		0.098
A2	0		0.10	0		0.004
B	0.66		0.86	0.026		0.034
B2	5.18		5.48	0.202		0.216
C	0.40		0.60	0.016		0.024
C2	0.44		0.58	0.017		0.023
D	5.90		6.30	0.232		0.248
D1	5.30REF			0.209REF		
E	6.40		6.80	0.252		0.268
E1	4.63			0.182		
G	4.47		4.67	0.176		0.184
H	9.50		10.70	0.374		0.421
L	1.09		1.21	0.043		0.048
L2	1.35		1.65	0.053		0.065
V1		7°			7°	
V2	0°		6°	0°		6°

CST65N06 Reel Specification-TO-252-4R

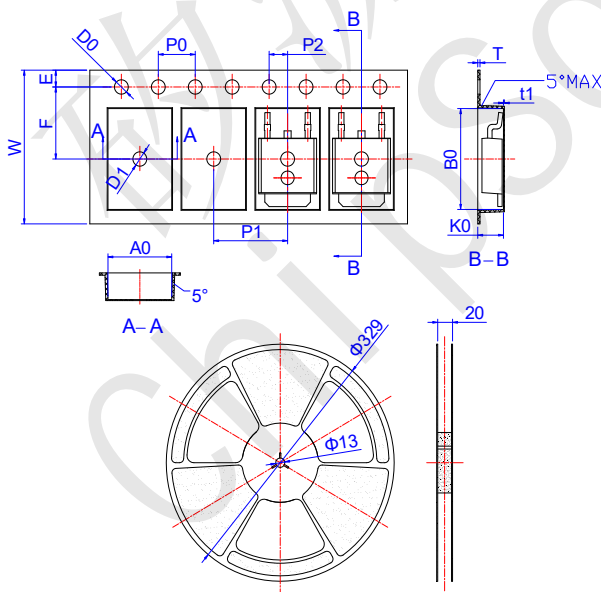

Ref.	Dimensions					
	Millimeters			Inches		
	Min.	Typ.	Max.	Min.	Typ.	Max.
W	15.90	16.00	16.10	0.626	0.630	0.634
E	1.65	1.75	1.85	0.065	0.069	0.073
F	7.40	7.50	7.60	0.291	0.295	0.299
D0	1.40	1.50	1.60	0.055	0.059	0.063
D1	1.40	1.50	1.60	0.055	0.059	0.063
P0	3.90	4.00	4.10	0.154	0.157	0.161
P1	7.90	8.00	8.10	0.311	0.315	0.319
P2	1.90	2.00	2.10	0.075	0.079	0.083
A0	6.85	6.90	7.00	0.270	0.271	0.276
B0	10.45	10.50	10.60	0.411	0.413	0.417
K0	2.68	2.78	2.88	0.105	0.109	0.113
T	0.24		0.27	0.009		0.011
t1	0.10			0.004		
10P0	39.80	40.00	40.20	1.567	1.575	1.583