



CST80P02 P-Ch 20V Fast Switching MOSFETs

- ★ Super Low Gate Charge
- ★ Green Device Available
- ★ Excellent CdV/dt effect decline
- ★ Advanced high cell density Trench technology



CST80P02 Product Summary

BVDSS	RDS(on)	ID
-20V	3.8mΩ	-80A

CST80P02 Description

The CST80P02 is the high cell density trenched P-ch MOSFETs, which provide excellent RDS(on) and gate charge for most of the synchronous buck converter applications. The CST80P02 meet the RoHS and Green Product requirement with full function reliability approved.

CST80P02 TO252 Pin Configuration

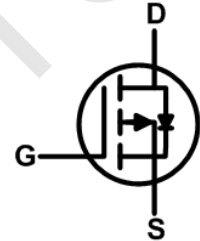
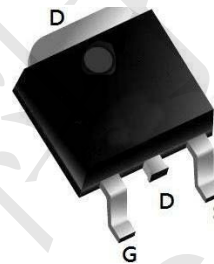

CST80P02 Absolute Maximum Ratings (TA = 25°C, unless otherwise noted)

Parameter	Symbol	Value	Unit
Drain-Source Voltage	V _{DS}	-20	V
Gate-Source Voltage	V _{GS}	±12	V
Continuous Drain Current	I _D	T _C =25°C	-80
		T _C =100°C	-44
Pulsed Drain Current ¹	I _{DM}	-280	A
Single Pulse Avalanche Energy ²	E _{AS}	80	mJ
Total Power Dissipation	P _D	43.1	W
		T _C =25°C	
Operating Junction and Storage Temperature Range	T _J , T _{STG}	-55 to 150	°C

Thermal Characteristics

Parameter	Symbol	Value	Unit
Thermal Resistance from Junction-to-Ambient ³	R _{θJA}	65	°C/W
Thermal Resistance from Junction-to-Case	R _{θJC}	2.9	°C/W



CST80P02 P-Ch 20V Fast Switching MOSFETs

CST80P02 Electrical Characteristics (T_J = 25°C, unless otherwise noted)

Parameter	Symbol	Test Conditions	Min.	Typ.	Max.	Unit	
Static Characteristics							
Drain-Source Breakdown Voltage	V _{(BR)DSS}	V _{GS} = 0V, I _D = -250μA	-20	-	-	V	
Gate-body Leakage current	I _{GSS}	V _{DS} = 0V, V _{GS} = ±12V	-	-	±100	nA	
Zero Gate Voltage Drain Current	I _{DSS}	V _{DS} = -20V, V _{GS} = 0V	T _J =25°C	-	-	-1	μA
			T _J =100°C	-	-	-100	
Gate-Threshold Voltage	V _{GS(th)}	V _{DS} = V _{GS} , I _D = -250μA	-0.4	-0.7	-1	V	
Drain-Source On-Resistance ⁴	R _{DS(on)}	V _{GS} = -4.5V, I _D = -10A	-	3.8	5.2	mΩ	
		V _{GS} = -2.5V, I _D = -10A	-	5	6.8		
Forward Transconductance ⁴	g _{fs}	V _{DS} = -4.5V, I _D = -10A	-	56	-	S	
Dynamic Characteristics⁵							
Input Capacitance	C _{iss}	V _{DS} = -10V, V _{GS} = 0V, f = 1MHz	-	4770	-	pF	
Output Capacitance	C _{oss}		-	665	-		
Reverse Transfer Capacitance	C _{rss}		-	570	-		
Gate Resistance	R _g	f = 1MHz	-	9.6	-	Ω	
Switching Characteristics⁵							
Total Gate Charge	Q _g	V _{GS} = -4.5V, V _{DS} = -10V, I _D = -10A	-	55	-	nC	
Gate-Source Charge	Q _{gs}		-	5.2	-		
Gate-Drain Charge	Q _{gd}		-	10	-		
Turn-On Delay Time	t _{d(on)}	V _{GS} = -4.5V, V _{DD} = -10V, R _G = 3Ω, I _D = -10A	-	22	-	ns	
Rise Time	t _r		-	38	-		
Turn-Off Delay Time	t _{d(off)}		-	110	-		
Fall Time	t _f		-	62	-		
Drain-Source Body Diode Characteristics							
Diode Forward Voltage ⁴	V _{SD}	I _S = -10A, V _{GS} = 0V	-	-	-1.2	V	
Continuous Source Current	I _S	T _C =25°C	-	-	-80	A	

Note :

1. Repetitive rating, pulse width limited by junction temperature T_{J(MAX)}=150°C.
2. The EAS data shows Max. rating. The test condition is V_{DD}= -25V, V_{GS}= -10V, L= 0.4mH, I_{AS}= -20A.
3. The data tested by surface mounted on a 1 inch² FR-4 board with 2OZ copper, The value in any given application depends on the user's specific board design.
4. The data tested by pulsed, pulse width ≤ 300us, duty cycle ≤ 2%.
5. This value is guaranteed by design hence it is not included in the production test.



CST80P02 Typical Characteristics

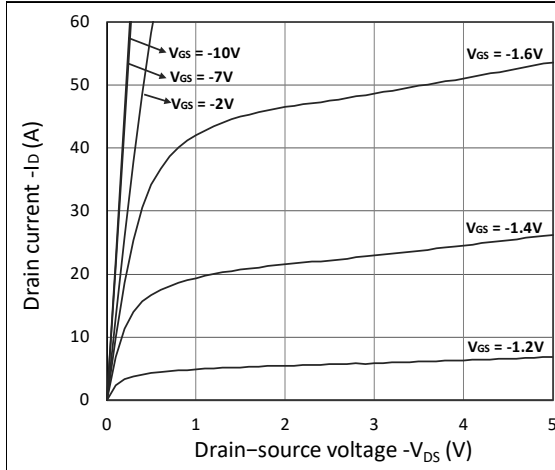

Figure 1. Output Characteristics

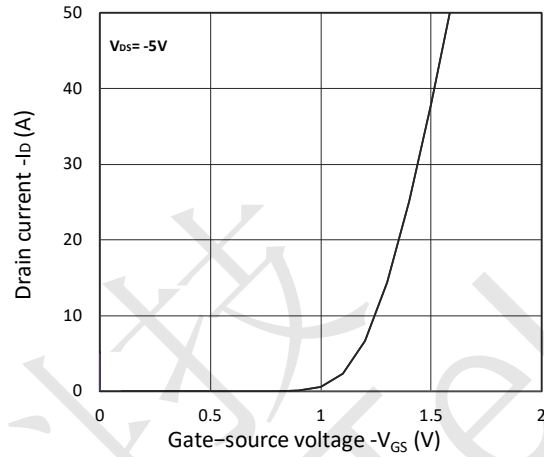

Figure 2. Transfer Characteristics

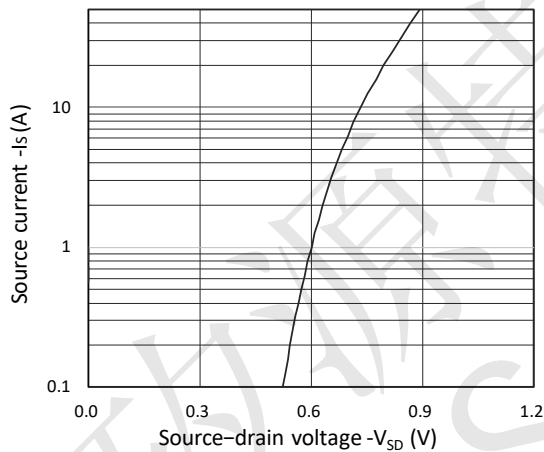

Figure 3. Forward Characteristics of Reverse

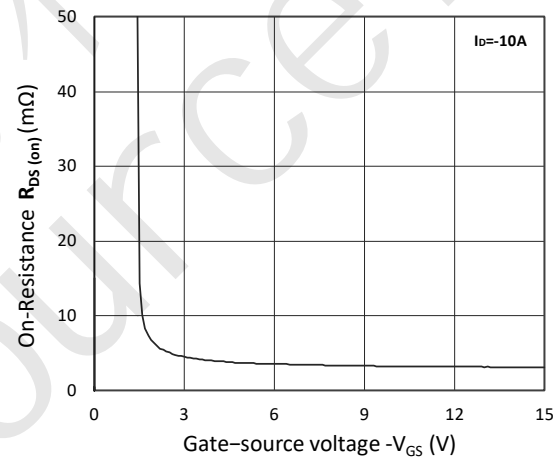

Figure 4. $R_{DS(on)}$ vs. V_{GS}

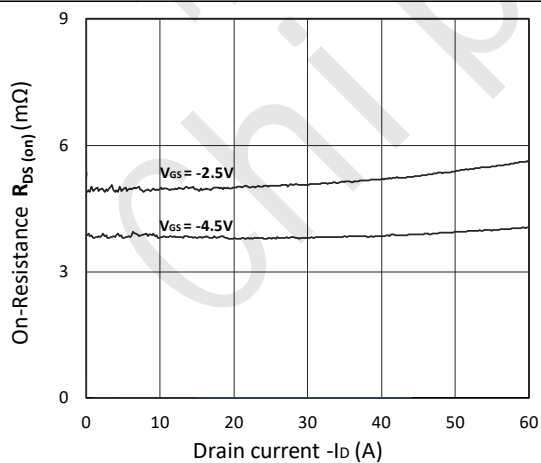

Figure 5. $R_{DS(on)}$ vs. I_D

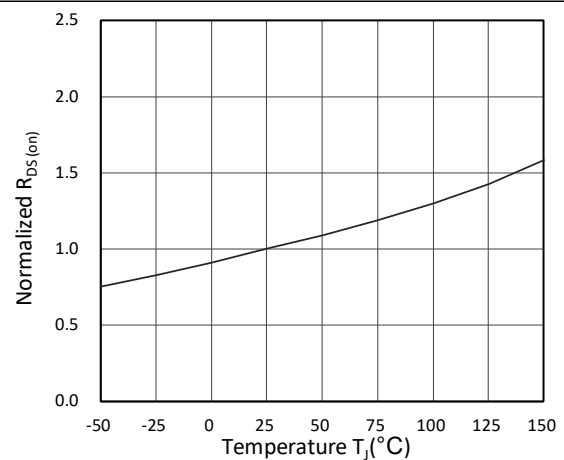

Figure 6. Normalized $R_{DS(on)}$ vs. Temperature



CST80P02 P-Ch 20V Fast Switching MOSFETs

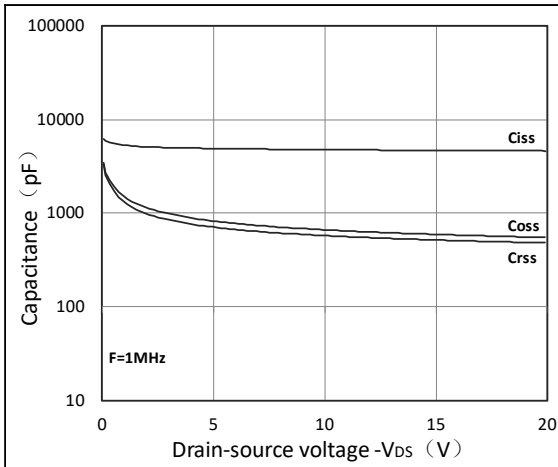

Figure 7. Capacitance Characteristics

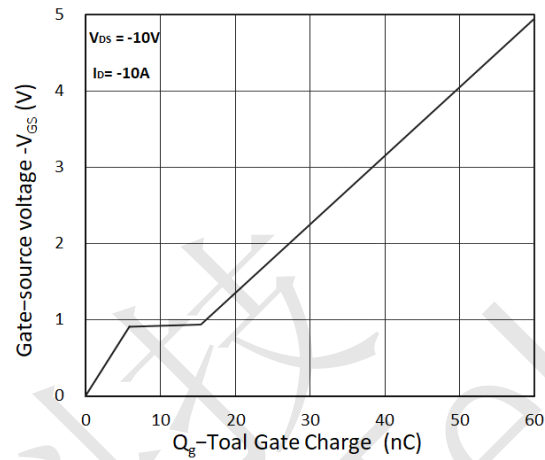

Figure 8. Gate Charge Characteristics

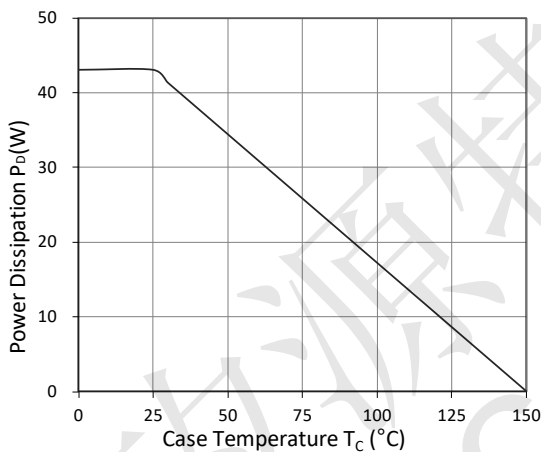

Figure 9. Power Dissipation

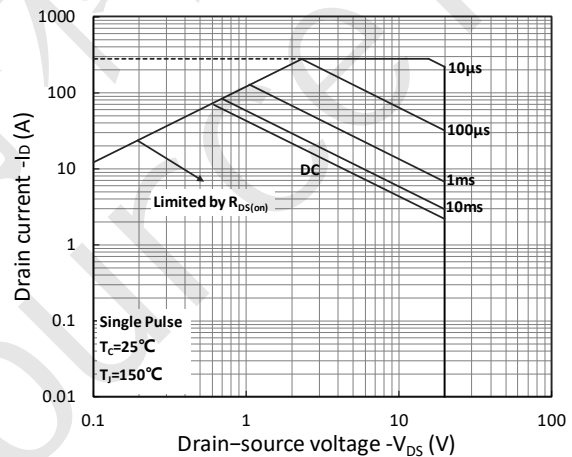

Figure 10. Safe Operating Area

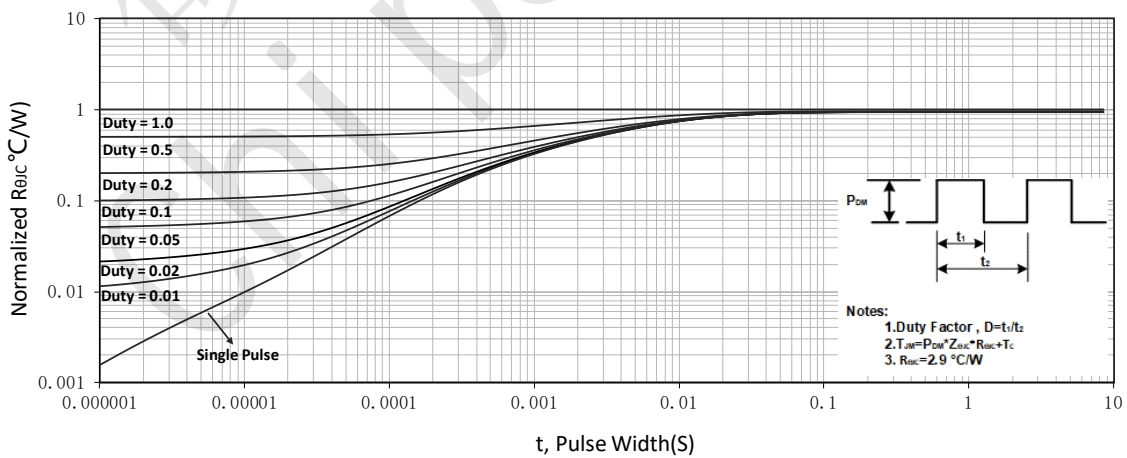
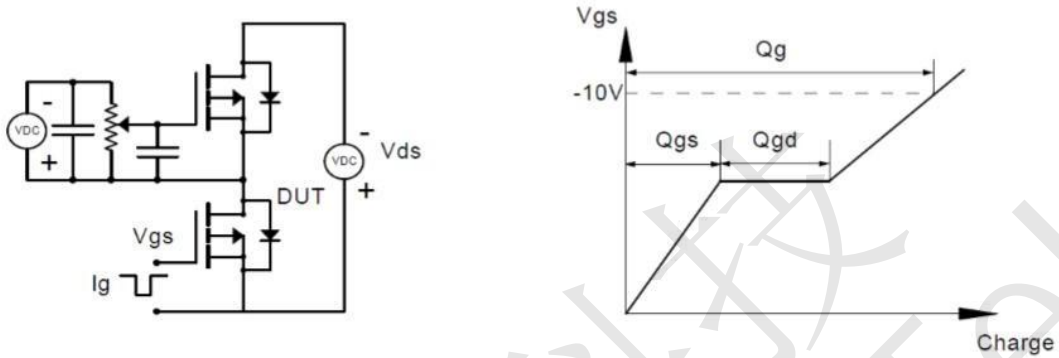

Figure 11. Normalized Maximum Transient Thermal Impedance



CST80P02 Test Circuit

Gate Charge Test Circuit & Waveform



Resistive Switching Test Circuit & Waveforms

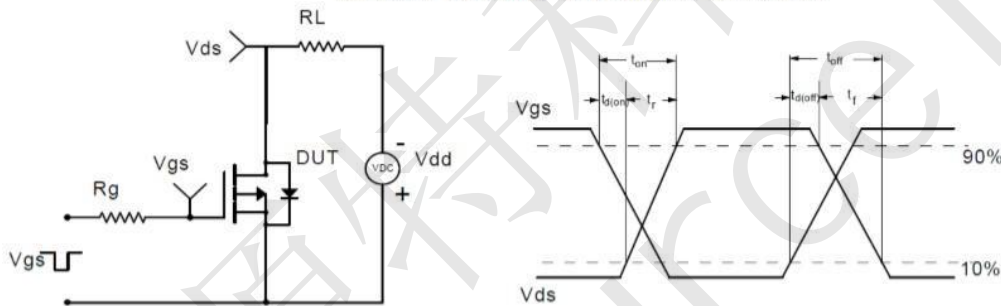

Unclamped Inductive Switching (UIS) Test Circuit & Waveforms

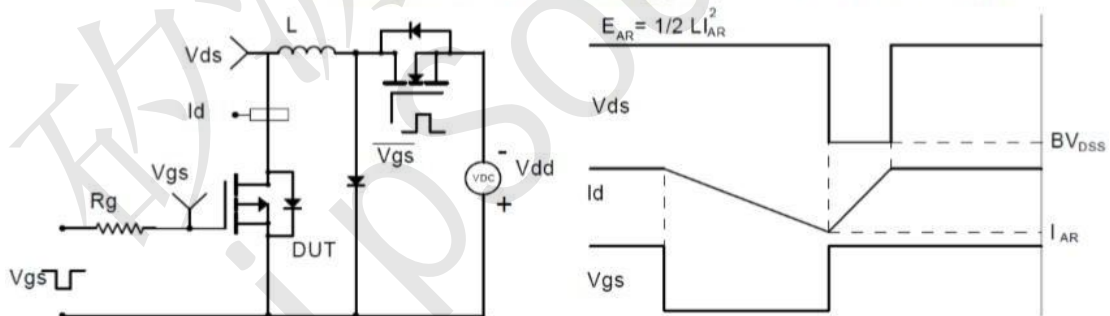

Diode Recovery Test Circuit & Waveforms

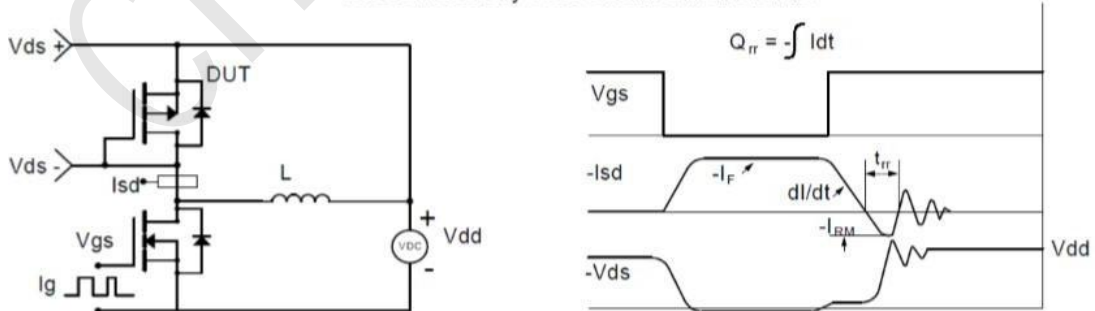



CST80P02 Package Mechanical Data-TO-252

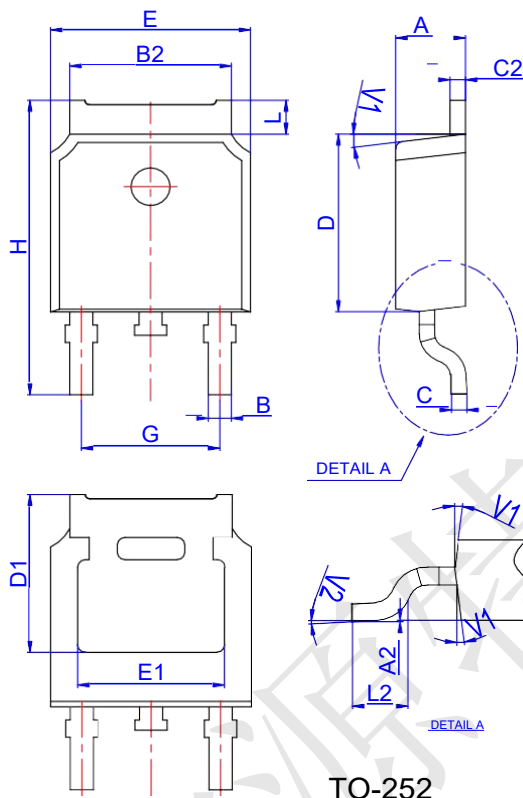

Ref.	Dimensions					
	Millimeters			Inches		
	Min.	Typ.	Max.	Min.	Typ.	Max.
A	2.10		2.50	0.083		0.098
A2	0		0.10	0		0.004
B	0.66		0.86	0.026		0.034
B2	5.18		5.48	0.202		0.216
C	0.40		0.60	0.016		0.024
C2	0.44		0.58	0.017		0.023
D	5.90		6.30	0.232		0.248
D1	5.30REF			0.209REF		
E	6.40		6.80	0.252		0.268
E1	4.63			0.182		
G	4.47		4.67	0.176		0.184
H	9.50		10.70	0.374		0.421
L	1.09		1.21	0.043		0.048
L2	1.35		1.65	0.053		0.065
V1		7°			7°	
V2	0°		6°	0°		6°

CST80P02 Reel Specification-TO-252-4R

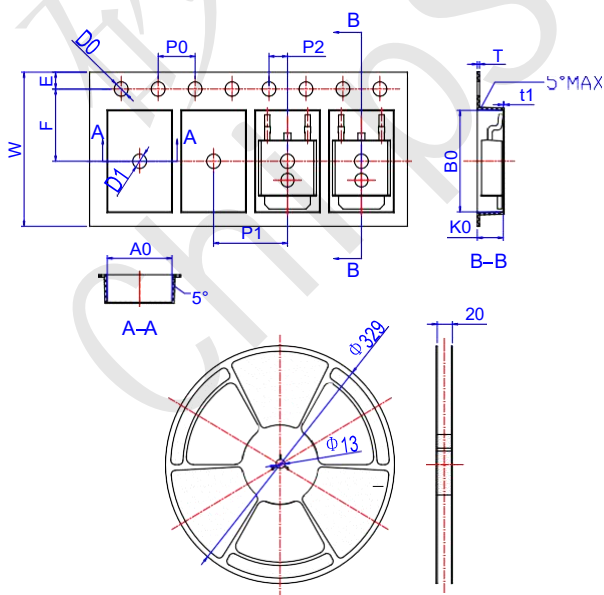

Ref.	Dimensions					
	Millimeters			Inches		
	Min.	Typ.	Max.	Min.	Typ.	Max.
W	15.90	16.00	16.10	0.626	0.630	0.634
E	1.65	1.75	1.85	0.065	0.069	0.073
F	7.40	7.50	7.60	0.291	0.295	0.299
D0	1.40	1.50	1.60	0.055	0.059	0.063
D1	1.40	1.50	1.60	0.055	0.059	0.063
P0	3.90	4.00	4.10	0.154	0.157	0.161
P1	7.90	8.00	8.10	0.311	0.315	0.319
P2	1.90	2.00	2.10	0.075	0.079	0.083
A0	6.85	6.90	7.00	0.270	0.271	0.276
B0	10.45	10.50	10.60	0.411	0.413	0.417
K0	2.68	2.78	2.88	0.105	0.109	0.113
T	0.24		0.27	0.009		0.011
t1	0.10			0.004		
10P0	39.80	40.00	40.20	1.567	1.575	1.583