



CST80P04F P-Ch 40V Fast Switching MOSFETs

- ★ Super Low Gate Charge
- ★ 100% EAS Guaranteed
- ★ Green Device Available
- ★ Excellent CdV/dt effect decline
- ★ Advanced high cell density Trench technology

CST80P04F Product Summary



BVDSS	RDSON	ID
-40V	4.3mΩ	-80 A

CST80P04F Description

The CST80P04F is the high cell density trenched P-ch MOSFETs, which provide excellent RDSON and gate charge for most of the synchronous buck converter applications. The CST80P04F meet the RoHS and Green Product requirement, 100% EAS guaranteed with full function reliability approved.

CST80P04F PDFN5060-8L Pin Configuration

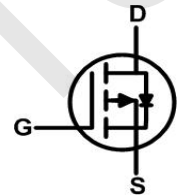
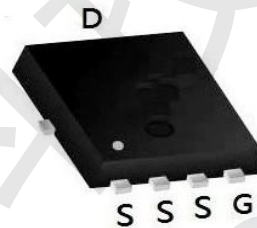

CST80P04F Absolute Maximum Ratings

Symbol	Parameter	Rating	Units
V_{DS}	Drain-Source Voltage	-40	V
V_{GS}	Gate-Source Voltage	±20	V
$I_D@T_C=25^{\circ}C$	Continuous Drain Current, $V_{GS} @ -10V^{1,6}$	-80	A
$I_D@T_C=100^{\circ}C$	Continuous Drain Current, $V_{GS} @ -10V^{1,6}$	-56	A
I_{DM}	Pulsed Drain Current ²	-320	A
EAS	Single Pulse Avalanche Energy ³	576	mJ
I_{AS}	Avalanche Current	-56	A
$P_D@T_C=25^{\circ}C$	Total Power Dissipation ⁴	58	W
T_{STG}	Storage Temperature Range	-55 to 175	°C
T_J	Operating Junction Temperature Range	-55 to 175	°C

CST80P04F Thermal Data

Symbol	Parameter	Typ.	Max.	Unit
$R_{\theta JA}$	Thermal Resistance Junction-ambient ¹ ($t \leq 10S$)	---	20	°C/W
	Thermal Resistance Junction-ambient ¹ (Steady State)	---	50	°C/W
$R_{\theta JC}$	Thermal Resistance Junction-case ¹	---	1.6	°C/W



CST80P04F P-Ch 40V Fast Switching MOSFETs

CST80P04F Electrical Characteristics ($T_J=25\text{ }^\circ\text{C}$, unless otherwise noted)

Symbol	Parameter	Conditions	Min	Typ	Max	Unit
On/Off States						
BV_{DSS}	Drain-Source Breakdown Voltage	$V_{GS}=0V, I_D=-250\mu A$	-40			V
I_{DSS}	Zero Gate Voltage Drain Current	$V_{DS}=-40V, V_{GS}=0V$			-1	μA
I_{GSS}	Gate-Body Leakage Current	$V_{GS}=\pm 20V, V_{DS}=0V$			± 100	nA
$V_{GS(th)}$	Gate Threshold Voltage	$V_{DS}=V_{GS}, I_D=-250\mu A$	-1	-1.7	-2.5	V
g_{FS}	Forward Transconductance	$V_{DS}=-5V, I_D=-20A$		63		S
$R_{DS(ON)}$	Drain-Source On-State Resistance	$V_{GS}=-10V, I_D=-20A$		4.3	5.3	m Ω
		$V_{GS}=-4.5V, I_D=-20A$		5.9	7.6	m Ω
Dynamic Characteristics						
C_{iss}	Input Capacitance	$V_{DS}=-20V, V_{GS}=0V, f=1.0MHz$		6638		pF
C_{oss}	Output Capacitance			545		pF
C_{rss}	Reverse Transfer Capacitance			345		pF
R_g	Gate resistance	$V_{GS}=0V, V_{DS}=0V, f=1.0MHz$		2.2		Ω
Switching Parameters						
$t_{d(on)}$	Turn-on Delay Time	$V_{GS}=-10V, V_{DS}=-20V, R_L=1\Omega, R_{GEN}=3\Omega$		16		nS
t_r	Turn-on Rise Time			17		nS
$t_{d(off)}$	Turn-Off Delay Time			68		nS
t_f	Turn-Off Fall Time			31		nS
Q_g	Total Gate Charge				118	
Q_{gs}	Gate-Source Charge	$V_{GS}=-10V, V_{DS}=-20V, I_D=-20A$		13		nC
Q_{gd}	Gate-Drain Charge			22		nC
Source-Drain Diode Characteristics						
I_{SD}	Source-Drain Current (Body Diode)				-80	A
V_{SD}	Forward on Voltage (Note 3)	$V_{GS}=0V, I_S=-20A$			-1.2	V
t_{rr}	Reverse Recovery Time	$I_F=-20A, di/dt=500A/\mu s$		24		ns
Q_{rr}	Reverse Recovery Charge	$I_F=-20A, di/dt=500A/\mu s$		140		nC

Notes 1.Repetitive Rating: Pulse width limited by maximum junction temperature.

Notes 2. E_{AS} condition: $T_J=25\text{ }^\circ\text{C}, V_{DD}=15V, V_G=-10V, R_g=25\Omega, L=0.5mH$.

Notes 3.Repetitive Rating: Pulse width limited by maximum junction temperature.



CST80P04F Typical Electrical And Thermal Characteristics (Curves)

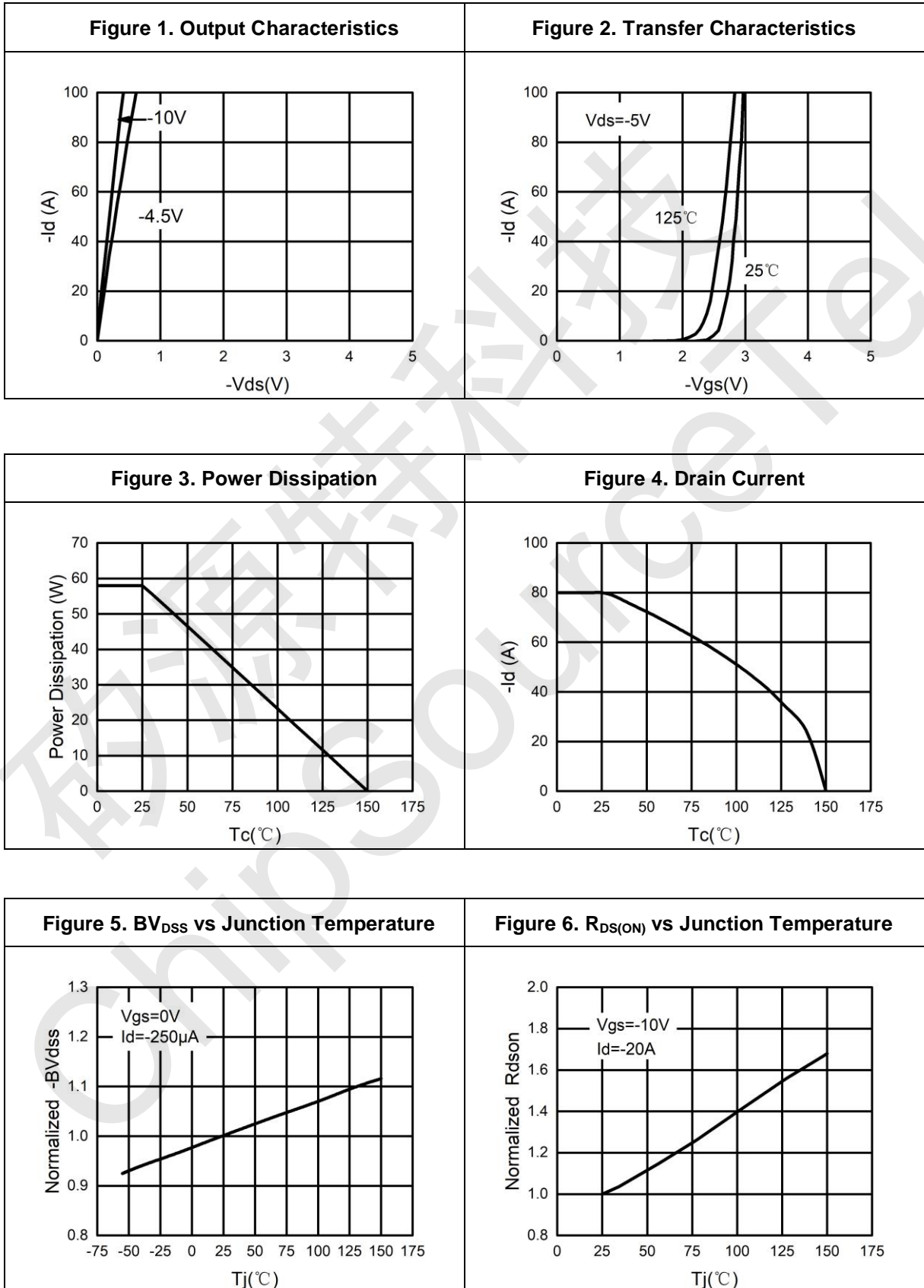



CST80P04F P-Ch 40V Fast Switching MOSFETs

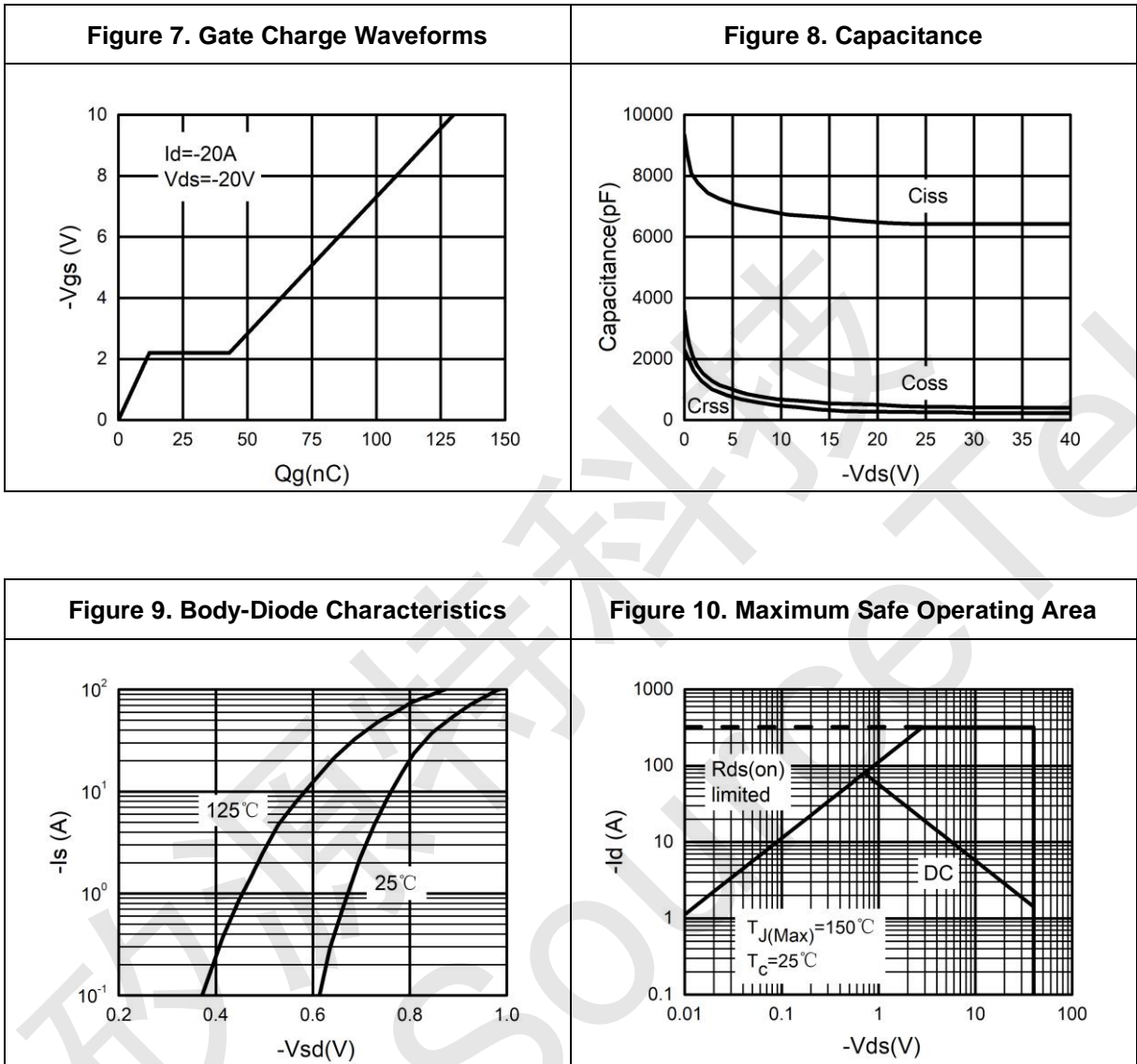



CST80P04F Test Circuit

1) E_{AS} Test Circuits

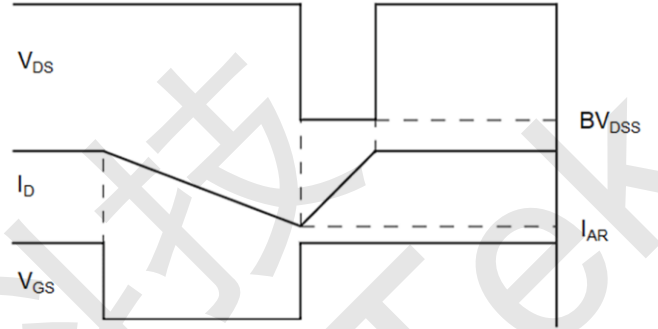
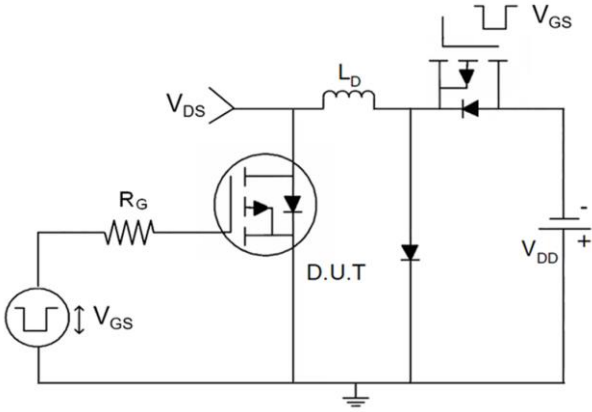

2) Gate Charge Test Circuit

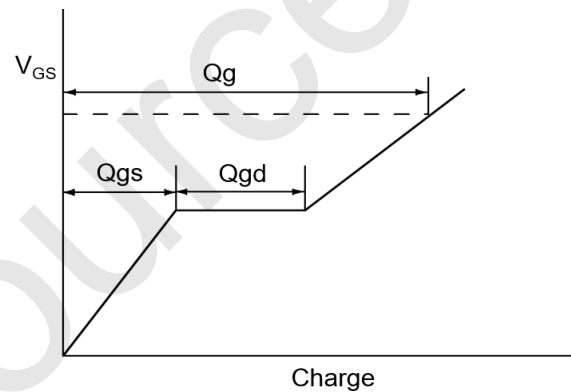
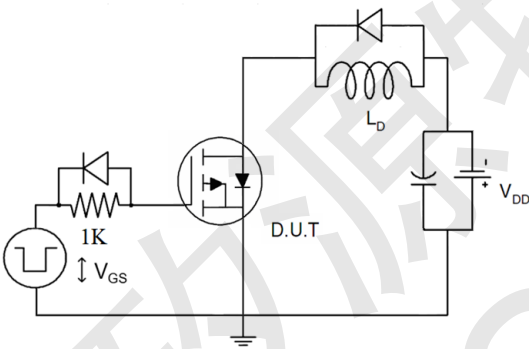

3) Switch Time Test Circuit

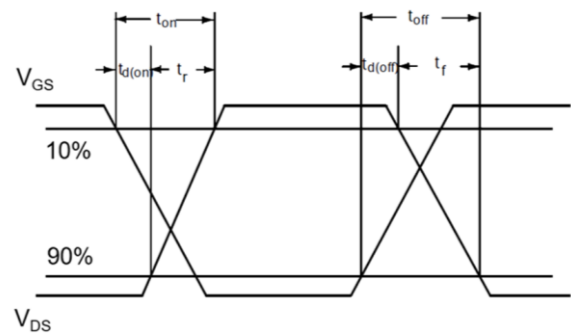
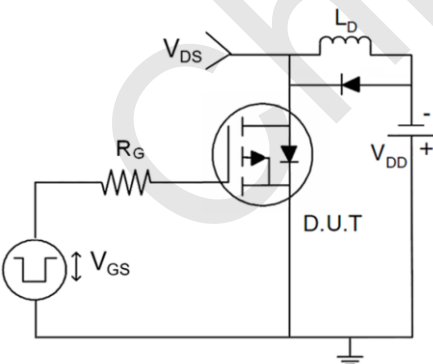



CST80P04F Package Mechanical Data-PDFN5060-8L-JQ Single

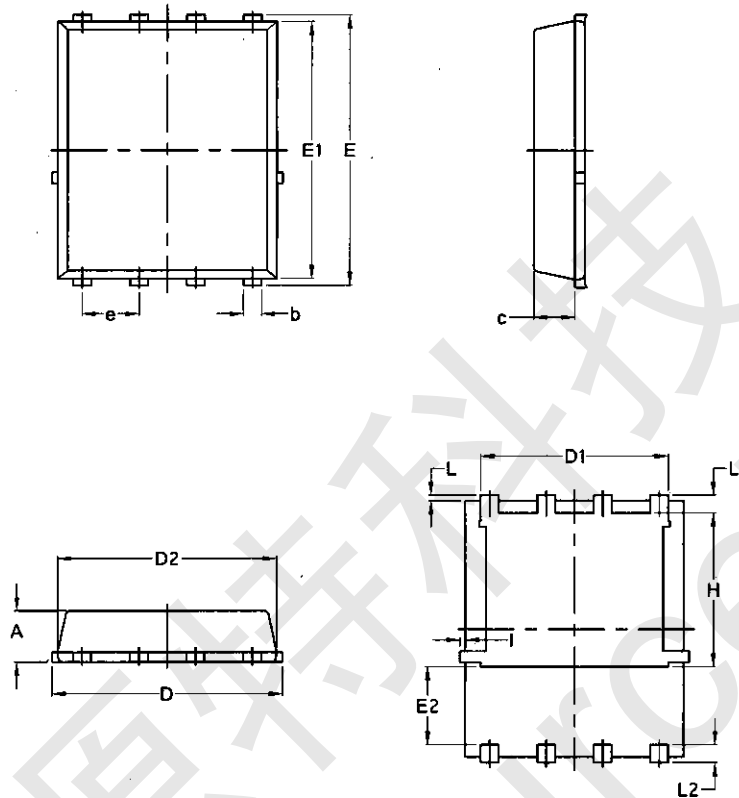

Symbol	Common			
	mm		Inch	
	Min	Max	Min	Max
A	1.03	1.17	0.0406	0.0461
b	0.34	0.48	0.0134	0.0189
c	0.824	0.0970	0.0324	0.082
D	4.80	5.40	0.1890	0.2126
D1	4.11	4.31	0.1618	0.1697
D2	4.80	5.00	0.1890	0.1969
E	5.95	6.15	0.2343	0.2421
E1	5.65	5.85	0.2224	0.2303
E2	1.60	/	0.0630	/
e	1.27 BSC		0.05 BSC	
L	0.05	0.25	0.0020	0.0098
L1	0.38	0.50	0.0150	0.0197
L2	0.38	0.50	0.0150	0.0197
H	3.30	3.50	0.1299	0.1378
I	/	0.18	/	0.0070