



Small Package, High Performance, Asynchronies Boost For 10 WLED Driver

ME2212 General Description

The ME2212 is a high frequency, asynchronous boost converter. The internal MOSFET can support up to 10 White LEDs for backlighting and OLED power application, and the internal soft start function can reduce the inrush current. The device operates with 1-MHz fixed switching frequency to allow small external components and to simplify possible EMI problems. Moreover, the IC comes with 46V over voltage protection to allow inexpensive and small-output capacitors with lower voltage ratings. The LED current is initially set with the external sense resistor R_s .

ME2212 Features

- VIN Operating Range : 2.5V to 5.5V
- Internal Power N-MOSFET Switch
- Wide Range for PWM Dimming (100Hz to 200kHz)
- 1MHz Switching Frequency
- Minimize the External Component Counts
- Internal Soft Start
- Internal Compensation
- Under Voltage Protection
- Over Voltage Protection
- Over Temperature Protection

ME2212 Typical Application

- Cellular Phones
- Digital still cameras
- PDAs and Smart Phones and MP3 and OLED.
- Probable Instruments

ME2212 Package

- 6-pin SOT23-6

ME2212 Typical Application Circuit

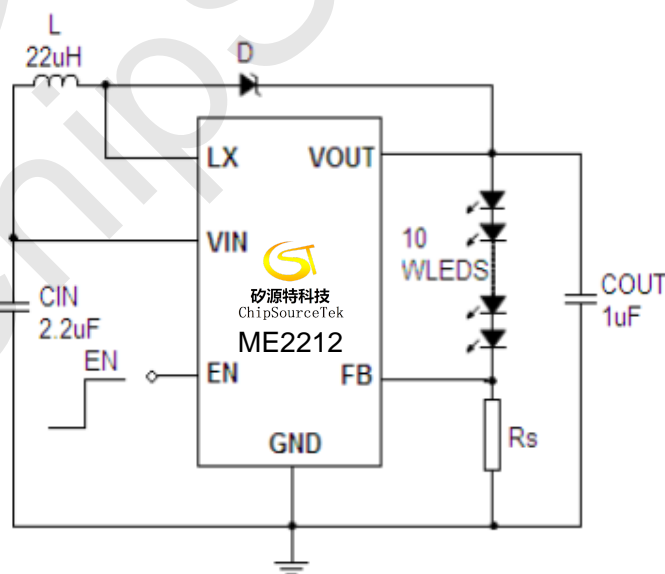

$$I_{LED} = 20\text{mA}, \quad R_s = 10\Omega$$



ME2212 Selection Guide

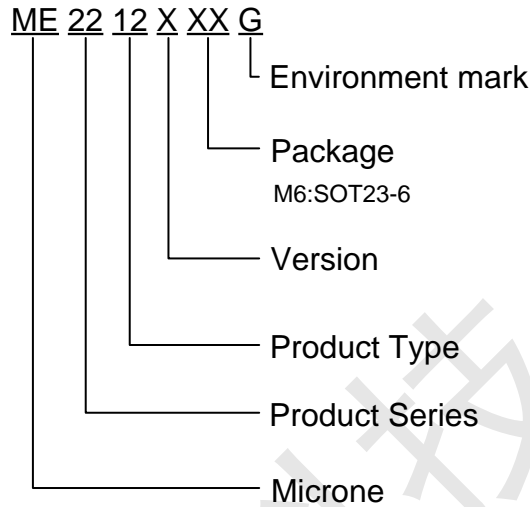

product series	product description
ME2212AM6G	Package: SOT23-6

NOTE: If you need other voltage and package, please contact our sales staff.

ME2212 Pin Configuration & Pin Assignment



ME2212 Pin Assignment

Pin Number	Name	Function
1	LX	Switch
2	GND	Ground
3	FB	Feedback
4	EN	Chip Enable
5	VOUT	Output
6	VIN	Input



ME2212 Block Diagram

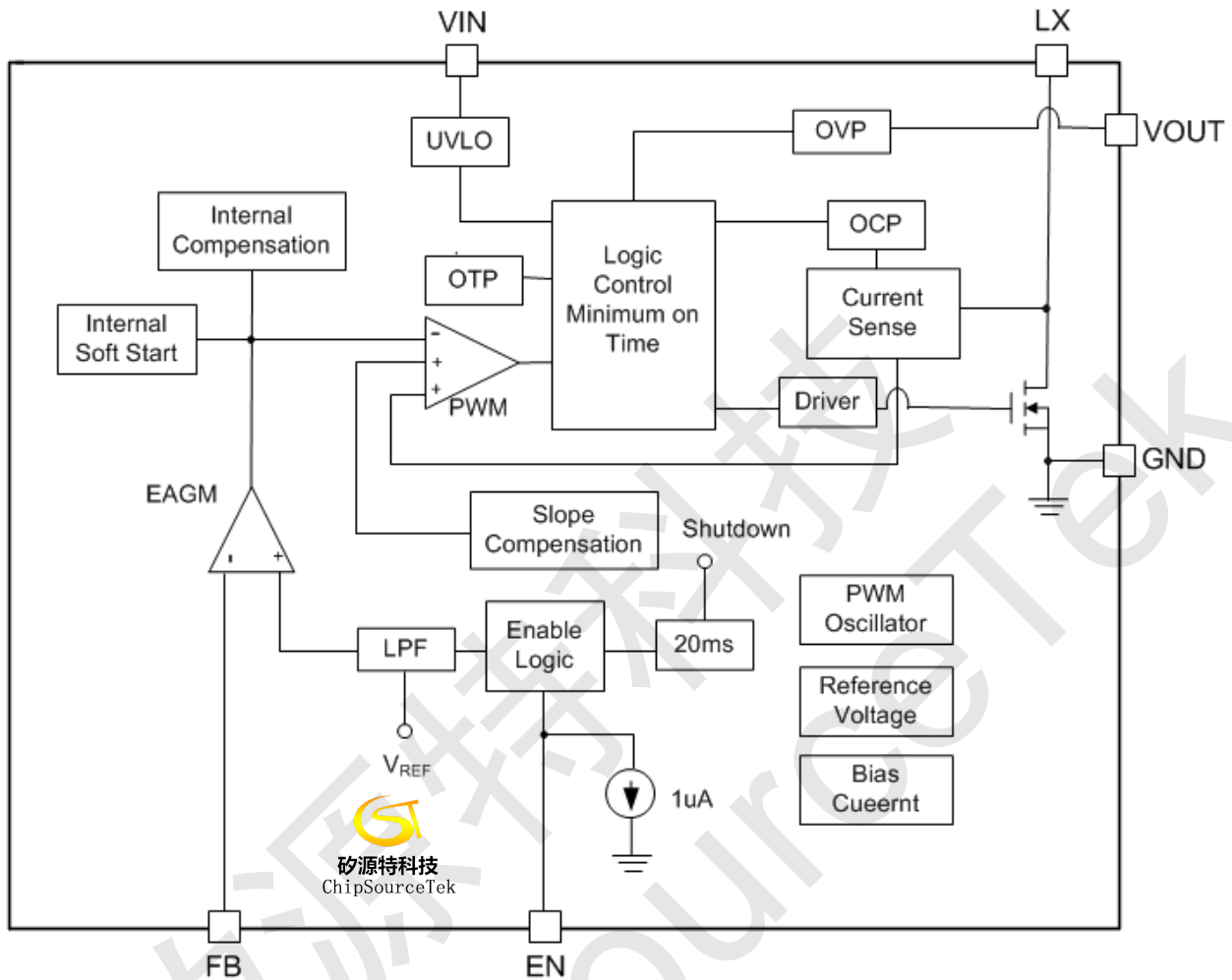

ME2212 Absolute Maximum Ratings

Parameter	Symbol	Ratings	Units
Input Voltage	V_{IN}	-0.3V~6V	V
LX Pin Voltage	LX	-0.3V~50V	V
FB Pin Voltage	FB	-0.3V~6V	V
Operating Temperature Range	T_{OPR}	-40°C~85°C	°C
Storage Temperature Range	T_{STG}	-65°C~125°C	°C
Lead Temperature (Soldering, 10 sec)	T_L	260°C	°C
Internal Power Dissipation (SOT23-6)	P_D	400	mW



ME2212 Electrical Characteristic

$T=25^{\circ}\text{C}$, $V_{\text{IN}}=V_{\text{EN}}=3.7\text{V}$, $L=22\mu\text{H}$, $C_{\text{IN}}=2.2\mu\text{F}$, $C_{\text{OUT}}=1\mu\text{F}$, unless otherwise noted.

Parameter	Symbol	Condition	Min	Typ	Max	Unit
Input Voltage Range	V_{IN}		2.5	3.7	5.5	V
Under Voltage Lock Out	V_{UVLO}		2	2.2	2.45	V
UVLO Hystersis				0.1		V
Supply Current	ISS	No external Component		0.8	1.5	mA
Shutdown Current	I_{SHDN}	No external Component $V_{\text{EN}}=0\text{V}$	1	3	5	μA
Oscillator Frequency	F_{OSC}		0.85	1.1	1.5	MHz
Maximum Duty Cycle			90	92		%
Feedback Voltage	V_{FB}		190	200	210	mV
On Resistance	$R_{\text{DS(ON)}}$			0.7	1.2	Ω
EN Threshold	Logic-High Voltage	V_{IH}	1.6			V
	Logic-Low Voltage	V_{IL}			0.9	V
Over-Voltage Threshold	V_{OVP}		42	46	50	V
Over-Current Threshold	I_{OCP}		1	1.2		A
Efficiency	η	$I_{\text{LED}}=20\text{mA}$		85		%
Over Temperature Shutdown	OTS			150		$^{\circ}\text{C}$

ME2212 Typical Operating Characteristics

1. Efficiency vs. Output Current (3 White LEDs)

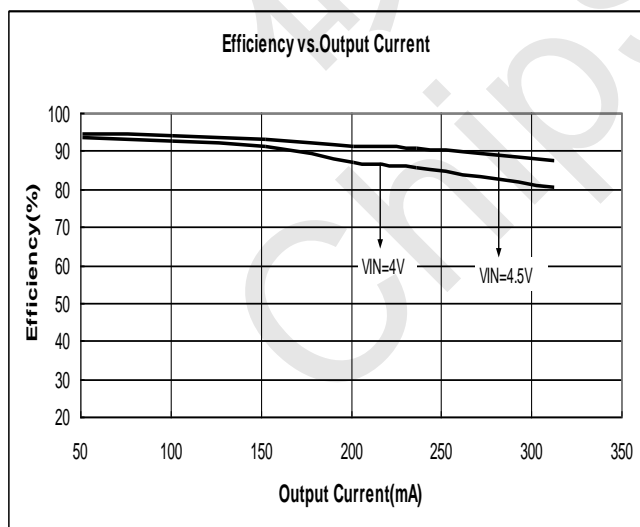

2. Efficiency vs. Input Voltage (10 White LEDs)

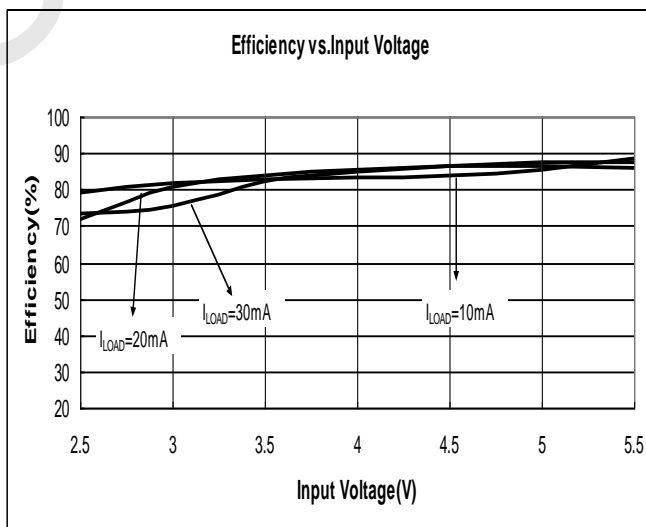



3. Frequency vs. Input Voltage ($I_{LED}=20mA$)

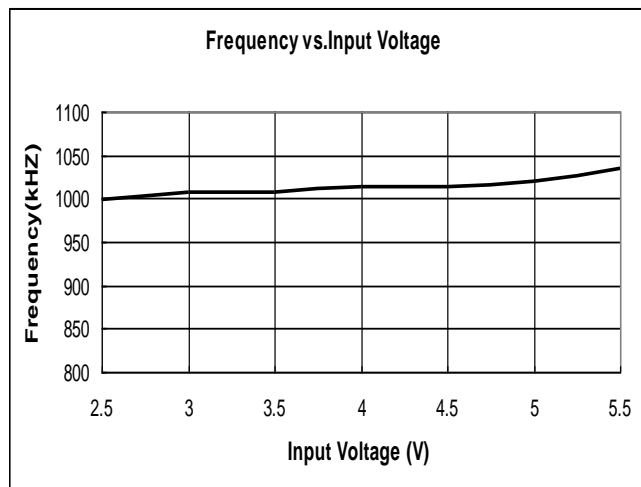

4. Frequency vs. Temperature ($V_{IN}=3.7V, I_{LED}=20mA$)

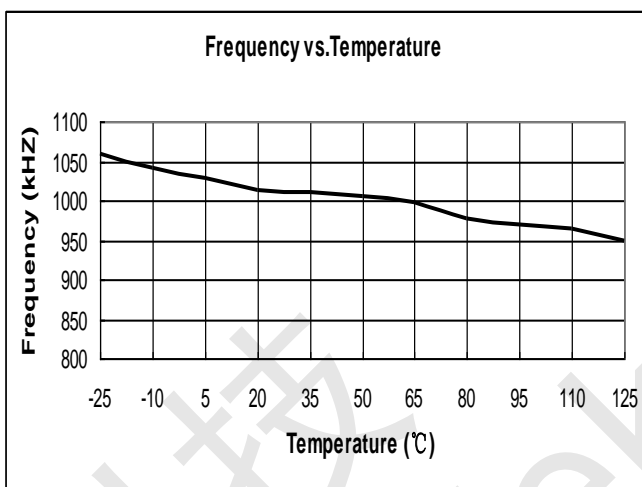

5. V_{FB} vs. Input Voltage (10 White LEDs, $I_{LED}=20mA$)

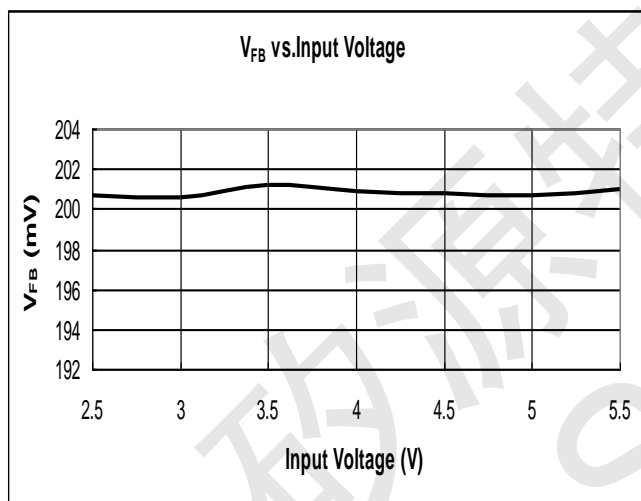

6. V_{FB} vs. Temperature ($I_{LED}=20mA$)

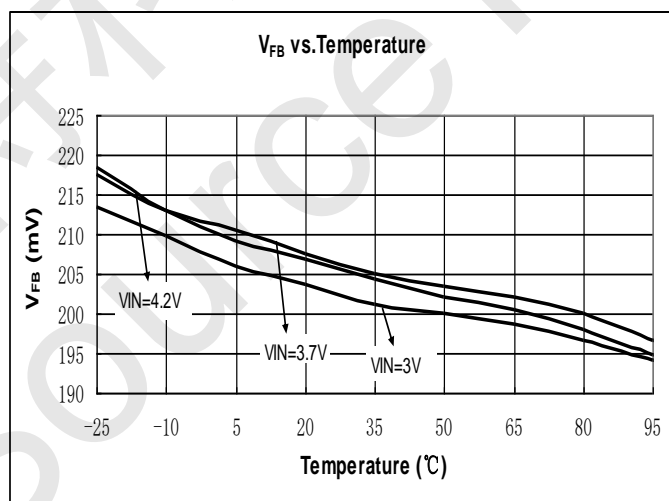

7. V_{FB} vs. Output Current (10 White LEDs)

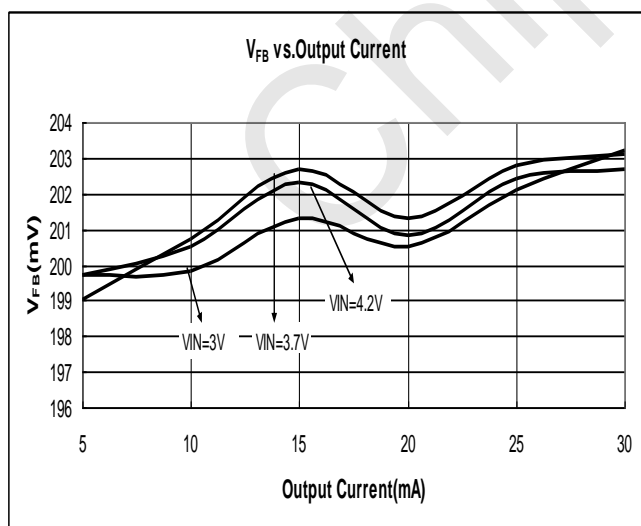

8. Enable Voltage vs. Input Voltage (10 White LEDs)

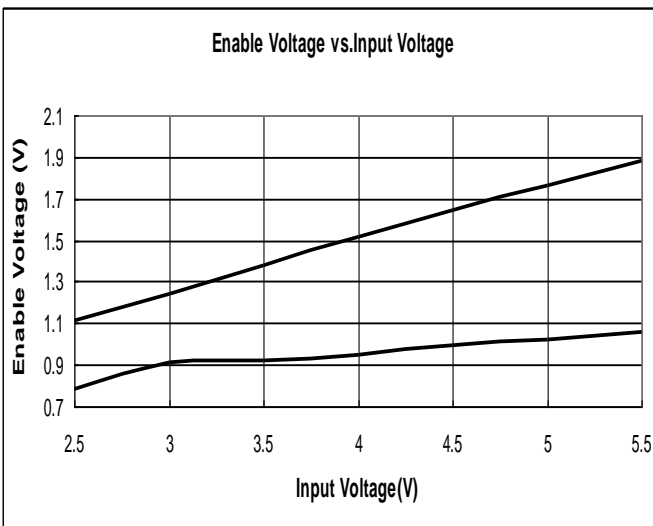



ME2212 Applications Information

LED Current Setting

The loop of Boost structure will keep the FB pin voltage equal to the reference voltage V_{FB} . Therefore, when R_S connects FB pin and GND, the current flows from V_{OUT} through LED and R_S to GND will be decided by the current on R_S , which is equal to following equation.

$$I_{LED} = \frac{V_{FB}}{R_S}$$

Dimming Control

a. Using a PWM Signal to EN Pin

For controlling the LED brightness, the ME2212 can perform the dimming control by applying a PWM signal to EN pin. A low pass filter is implemented inside chip to reduce the slew rate of I_{WLED} for preventing the audio noise. The internal soft start and the wide range dimming frequency from 200 to 200kHz can eliminate inrush current and audio noise when dimming. The average LED current is proportional to the PWM signal duty cycle. The magnitude of the PWM signal should be higher than the maximum enable voltage of EN pin, in order to let the dimming control perform correctly.

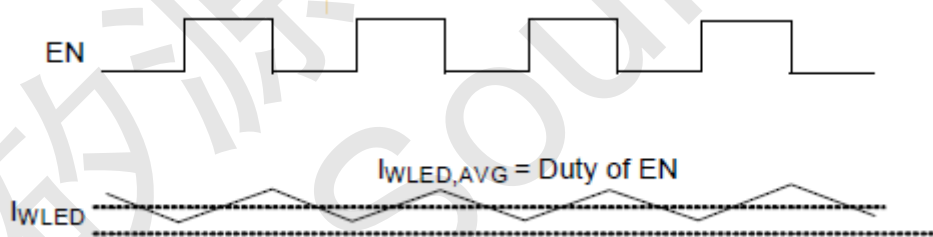

Figure 1. PWM Dimming

b. Using a DC Voltage

Using a variable DC voltage to adjust the brightness is a popular method in some applications. The dimming control using a DC voltage circuit is shown in Figure 2. As the DC voltage increases, the current pass through R_3 increasingly and the voltage drop on R_3 increase, i.e. the LED current decreases. For example, if the V_{DC} range is from 0V to 2.8V and assume the ME2212 is selected which V_{FB} is equal to 0.2V, the selection of resistors in Figure 2 sets the LED current from 21mA to 0mA. The LED current can be calculated by the following equation.

$$I_{LED} = \frac{V_{FB} - \frac{R_3 \times (V_{DC} - V_{FB})}{R_4}}{R_S}$$

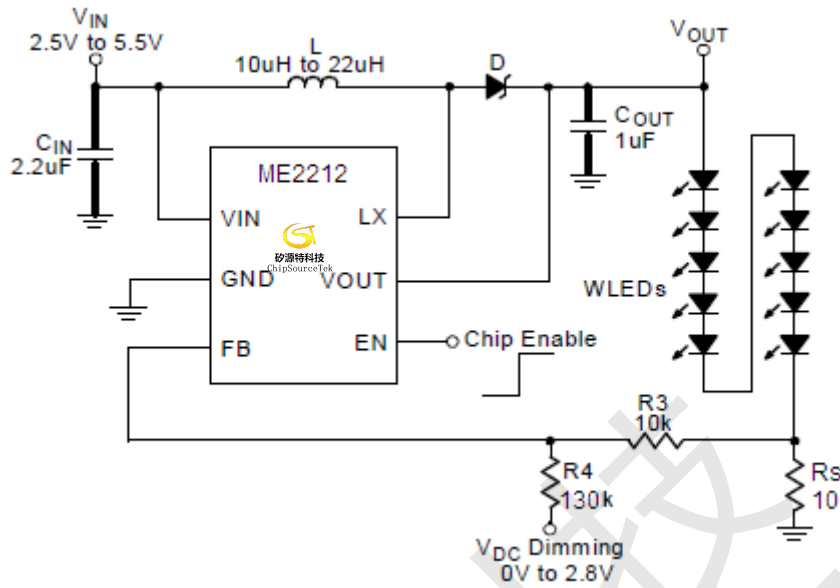

Figure 2. Dimming Control Using a DC Voltage for the ME2212

c. Using a Filtered PWM signal

Another common application is using a filtered PWM signal as an adjustable DC voltage for LED dimming control. A filtered PWM signal acts as the DC voltage to regulate the output current. The recommended application circuit is shown as Figure 3. In this circuit, the output ripple depends on the frequency of PWM signal. For smaller output voltage ripple (<100mV), the recommended frequency of 2.8V PWM signal should be above 2kHz. To fix the frequency of PWM signal and change the duty cycle of PWM signal can get different output current. The LED current can be calculated by the following equation.

$$I_{LED} = \frac{V_{FB} - \frac{R3 \times (V_{PWM} \times Duty - V_{FB})}{R4 + R_{DC}}}{R_s}$$

By the above equation and the application circuit shown in Figure 3, and assume the ME2212 is selected which V_{FB} is equal to 0.2V. Figure 4 shows the relationship between the LED current and PWM duty cycle. For example, when the PWM duty is equal to 60%, the LED current will be equal to 8.6mA. When the PWM duty is equal to 40%, the LED current will be equal to 12.9mA.

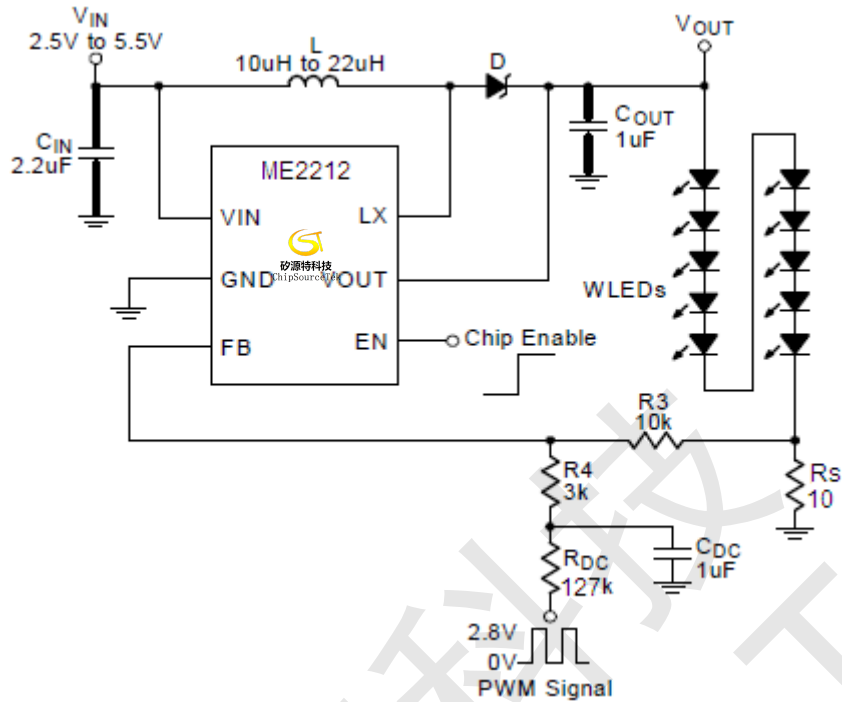

Figure 3. Filtered PWM Signal for LED Dimming Control of the ME2212

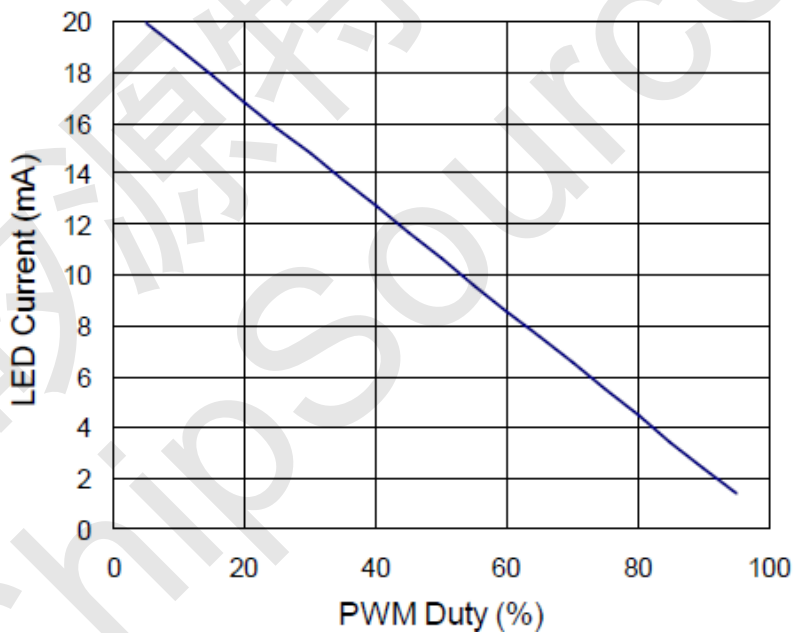

Figure 4

Application for Driving 3 x 13WLEDs

The ME2212 can driver different WLEDs topology. For example, the Figure 5 shows the 3x13WLEDs and total current is equal to 260mA. The total WLEDs current can be set by the R_S which is equal to following equation.

$$I_{\text{Total}} = \frac{V_{\text{FB}}}{R_S}$$

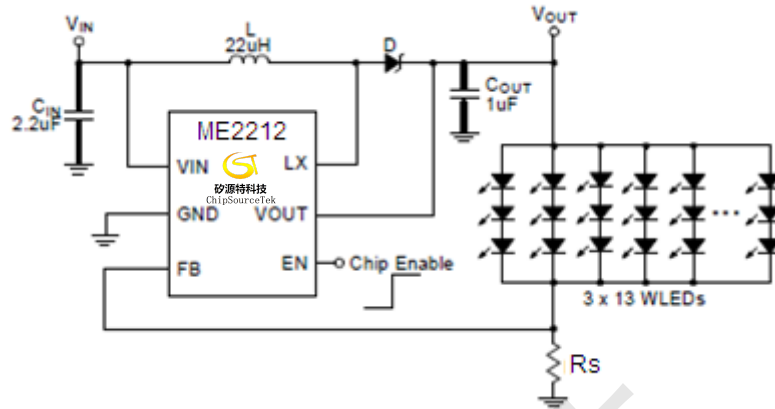

Figure 5. Application for Driving 3 X 13WLEDs

Soft-Start

The function of soft-start is made for suppressing the inrush current to an acceptable value at the beginning of power on. The soft-start function is built-in the ME2212 by clamping the output voltage of error amplifier so that the duty cycle of the PWM will be increased gradually in the soft-start period.

Current Limiting

The current flow through inductor as charging period is detected by a current sensing circuit. As the value comes across the current limiting threshold, the N-MOSFET will be turned off so that the inductor will be forced to leave charging stage and enter discharging stage. Therefore, the inductor current will not increase over the current limiting threshold.

OVP/UVLO/OTP

The Over Voltage Protection is detected by a junction breakdown detecting circuit. Once V_{OUT} goes over the detecting voltage, LX pin stops switching and the power N-MOSFET will be turned off. Then, the V_{OUT} will be clamped to be near V_{OVP} . As the output voltage is higher than a specified value or input voltage is lower than a specified value, the chip will enter protection mode to prevent abnormal function. As the die temperature $> 150^{\circ} C$, the chip also will enter protection mode. The power MOSFET will be turned off during protection mode to prevent abnormal operation.

Inductor Selection

The recommended value of inductor for 10 WLEDs applications is from 10uH to 22uH. Small size and better efficiency are the major concerns for portable devices, such as the ME2212 used for mobile phone. The inductor should have low core loss at 1MHz and low DCR for better efficiency. The inductor saturation current rating should be considered to cover the inductor peak current.

Capacitor Selection



Input ceramic capacitor of 2.2uF and output ceramic capacitor of 1uF are recommended for the ME2212 applications for driving 10 series WLEDs. For better voltage filtering, ceramic capacitors with low ESR are recommended. X5R and X7R types are suitable because of their wider voltage and temperature ranges.

ME2212 Layout Considerations

- A full GND plane without gap break.
- LX node copper area should be minimized for reducing EMI.
- The input capacitor CIN should be placed as close as possible to Pin 6.
- The output capacitor COUT should be connected directly from the Pin 5 to ground rather than across the LEDs.
- FB node copper area should be minimized and kept far away from noise sources (Pin 1, Pin 5, Pin 6).
- The Inductor is far away receiver and microphone.
- R_S should be placed as close as possible to the ME2212



ME2212 Package Information

- Package Type: SOT23-6

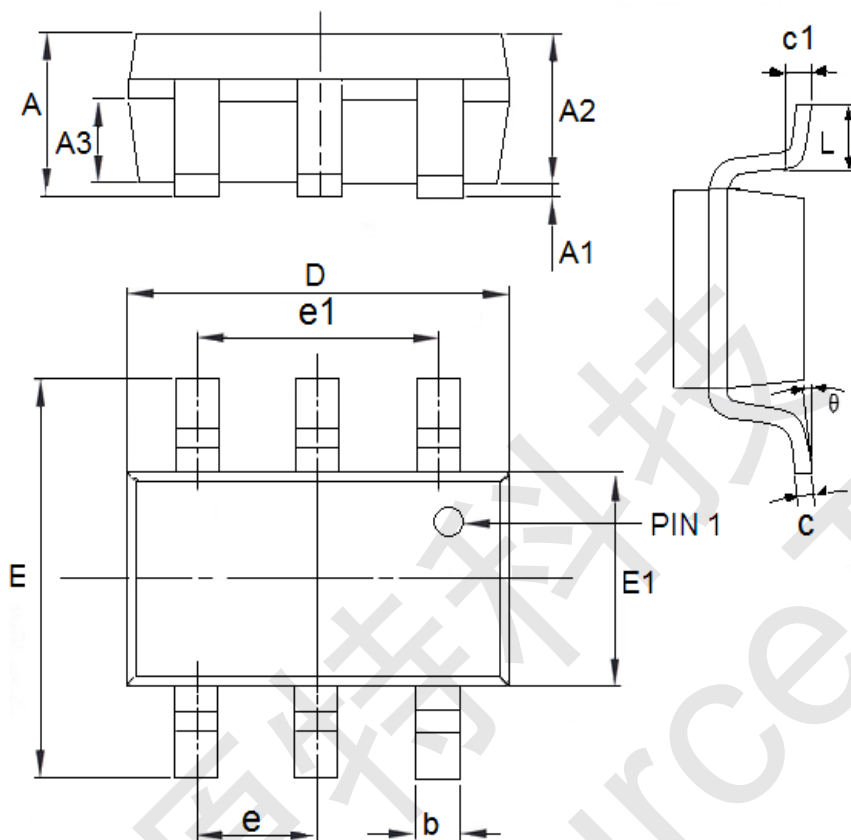

DIM	Millimeters		Inches	
	Min	Max	Min	Max
A	1.05	1.45	0.0413	0.0571
A1	0	0.15	0.0000	0.0059
A2	0.9	1.3	0.0354	0.0512
A3	0.55	0.75	0.0217	0.0295
b	0.25	0.5	0.0098	0.0197
c	0.1	0.25	0.0039	0.0098
D	2.7	3.12	0.1063	0.1228
e1	1.9(TYP)		0.0748(TYP)	
E	2.6	3.1	0.1024	0.1220
E1	1.4	1.8	0.0551	0.0709
e	0.95(TYP)		0.0374(TYP)	
L	0.25	0.6	0.0098	0.0236
theta	0	8°	0.0000	8°
c1	0.2(TYP)		0.0079(TYP)	



- The contents of this document will be updated with the product's improvement without prior notice. Please consult our sales staff before using this document to ensure that you are using the latest version.
- The application circuit examples described in this document are only used to indicate the representative use of the product and do not guarantee the design of mass production.
- Please use this product within the limits stated in this document. We will not be responsible for any damage caused by improper use.
- The products described in this document are not allowed to be used in equipment or devices that affect the human body without the written permission of our company, including but not limited to: health equipment, medical equipment, disaster prevention equipment, fuel control equipment, automobile equipment, aviation equipment and vehicle equipment.
- Although our company has always been committed to improving product quality and reliability, semiconductor products have a certain probability of malfunction or wrong work. To prevent personal injury or property damage caused by such accidents, please pay full attention to safety design, for example: Alternate design, fire protection design, and prevention of wrong action design.
- When exporting this product or this document overseas, you should abide by applicable import and export control laws.
- Copying or reprinting part or all of this document in any form without the permission of our company is strictly prohibited.