



MOT5N50C/MOT5N50D N-CHANNEL MOSFET

■ MOT5N50C/D PRODUCT CHARACTERISTICS

VDSS	500V
$R_{DS(on)typ}(V_{GS}=10V)$	1.2Ω
Qg@type	24nC
ID	5A

Symbol

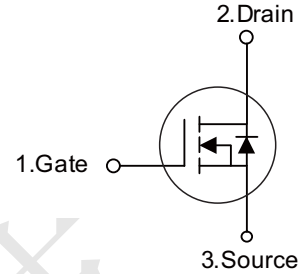

■ MOT5N50C/D APPLICATIONS

- High frequency switching mode power supply
- Electronic ballast
- LED power supply

■ MOT5N50C/D FEATURES

- * Fast Switching Capability
- * Avalanche Energy Specified
- * Improved dv/dt Capability, High Ruggedness

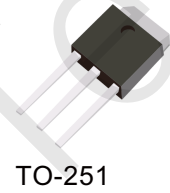

■ MOT5N50C/D ORDER INFORMATION

Order codes		Package	Packing
Halogen-Free	Halogen		
N/A	MOT5N50D	TO-252	2500 pieces /Reel
N/A	MOT5N50C	TO-251	70 pieces/Tube

■ MOT5N50C/D ABSOLUTE MAXIMUM RATINGS ($T_C = 25^\circ\text{C}$, unless otherwise specified)

PARAMETER	SYMBOL	RATINGS	UNIT
Drain-Source Voltage	V_{DSS}	500	V
Gate-Source Voltage	V_{GSS}	±30	V
Drain Current	Continuous	I_D	5
	Pulsed (Note 2)	I_{DM}	20
Avalanche Current (Note 2)	I_{AR}	5	A
Avalanche Energy	Single Pulsed (Note 3)	E_{AS}	300
	Repetitive (Note 2)	E_{AR}	7.3
Peak Diode Recovery dv/dt (Note 4)	dv/dt	4.5	V/ns
Power Dissipation	P_D	125	W
Junction Temperature	T_J	+150	°C
Storage Temperature	T_{STG}	-55~+150	°C

Note: 1. Absolute maximum ratings are those values beyond which the device could be permanently damaged.

Absolute maximum ratings are stress ratings only and functional device operation is not implied.

2. Repetitive Rating: Pulse width limited by maximum junction temperature

3. $L = 21.5\text{mH}$, $I_{AS} = 5\text{A}$, $V_{DD} = 50\text{V}$, $R_G = 25\Omega$, Starting $T_J = 25^\circ\text{C}$

4. $I_{SD} \leq 5\text{A}$, $di/dt \leq 200\text{A}/\mu\text{s}$, $V_{DD} \leq BV_{DSS}$, Starting $T_J = 25^\circ\text{C}$



■ MOT5N50C/D ELECTRICAL CHARACTERISTICS (T_C = 25°C, unless otherwise specified)

PARAMETER		SYMBOL	TEST CONDITIONS	MIN	TYP	MAX	UNIT	
OFF CHARACTERISTICS								
Drain-Source Breakdown Voltage		BV _{DSS}	I _D =250μA, V _{GS} =0V	500			V	
Breakdown Voltage Temperature Coefficient		ΔBV _{DSS} /ΔT _J	Reference to 25°C, I _D =250μA		0.5		V/°C	
Drain-Source Leakage Current		I _{DSS}	V _{DS} =500V, V _{GS} =0V			1	μA	
			V _{DS} =400V, T _C =125°C			10		
Gate- Source Leakage Current	Forward	I _{GSS}	V _{GS} =30V, V _{DS} =0V			100	nA	
	Reverse		V _{GS} =-30V, V _{DS} =0V			-100	nA	
ON CHARACTERISTICS								
Gate Threshold Voltage		V _{GS TH}	V _{DS} =V _{GS} , I _D =250μA	2.0		4.0	V	
Static Drain-Source On-State Resistance		R _{DS ON}	V _{GS} =10V, I _D =2.5A		1.2	1.5	Ω	
DYNAMIC PARAMETERS								
Input Capacitance		C _{ISS}	V _{GS} =0V, V _{DS} =25V, f=1.0MHz		480	625	pF	
Output Capacitance		C _{OSS}				80	105	pF
Reverse Transfer Capacitance		C _{RSS}				15	20	pF
SWITCHING PARAMETERS								
Total Gate Charge		Q _G	V _{GS} =10V, V _{DS} =400V, I _D =5A (Note 1, 2)		18	24	nC	
Gate to Source Charge		Q _{GS}			2.2		nC	
Gate to Drain Charge		Q _{GD}			9.7		nC	
Turn-ON Delay Time		t _{D ON}	V _{DD} =250V, I _D =5A, R _G =25Ω (Note 1, 2)		12	35	ns	
Rise Time		t _R			46	100	ns	
Turn-OFF Delay Time		t _{D OFF}			50	110	ns	
Fall-Time		t _F			48	105	ns	
SOURCE- DRAIN DIODE RATINGS AND CHARACTERISTICS								
Maximum Continuous Drain-Source Diode Forward Current		I _S				5	A	
Maximum Pulsed Drain-Source Diode Forward Current		I _{SM}				20	A	
Drain-Source Diode Forward Voltage		V _{SD}	I _S =5A, V _{GS} =0V			1.4	V	
Reverse Recovery Time		t _r	I _S =5A, V _{GS} =0V,		83		ns	
Reverse Recovery Charge		Q _{RR}	dI _F /dt=100A/μs (Note 1)		0.25		uC	

Note: 1. Pulse Test: Pulse width ≤ 300μs, Duty cycle ≤ 2%
2. Essentially independent of operating temperature



■ MOT5N50C/D TEST CIRCUITS AND WAVEFORMS

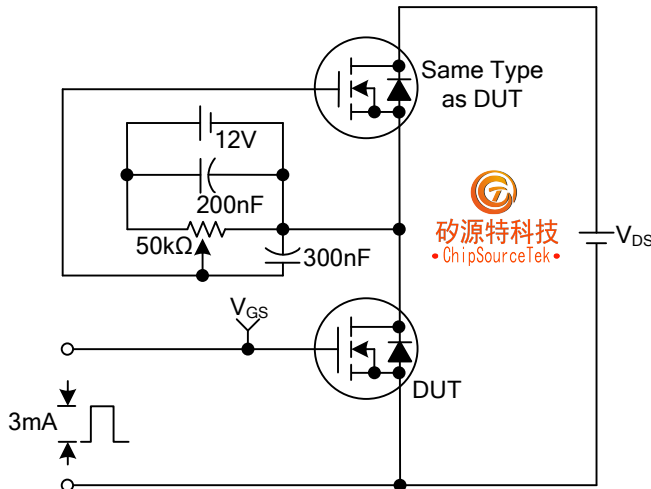

Gate Charge Test Circuit

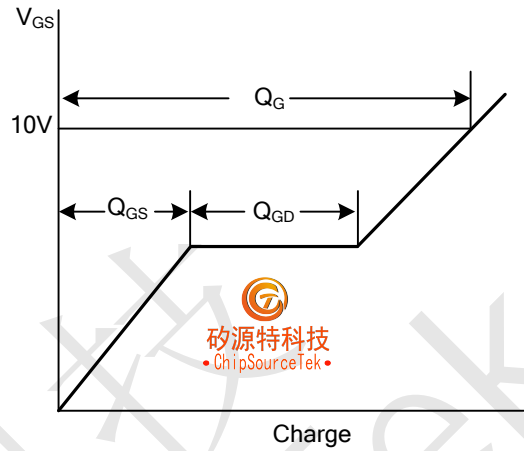

Gate Charge Waveforms

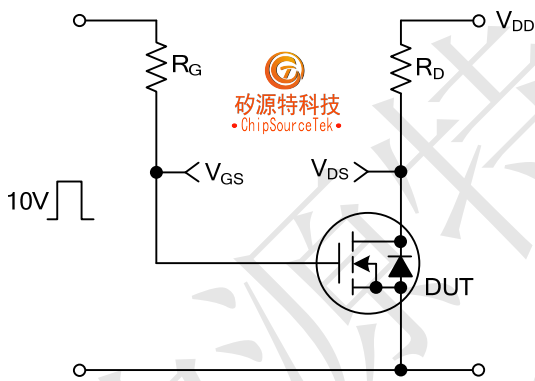

Resistive Switching Test Circuit

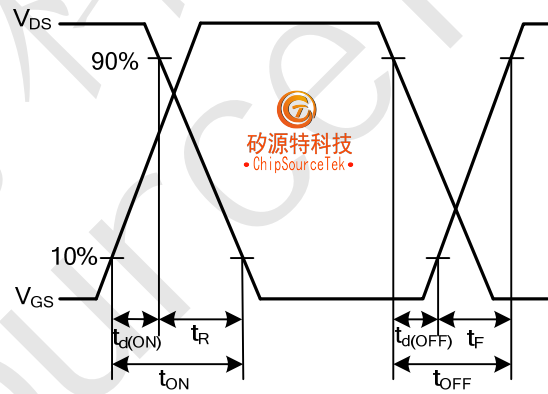

Resistive Switching Waveforms

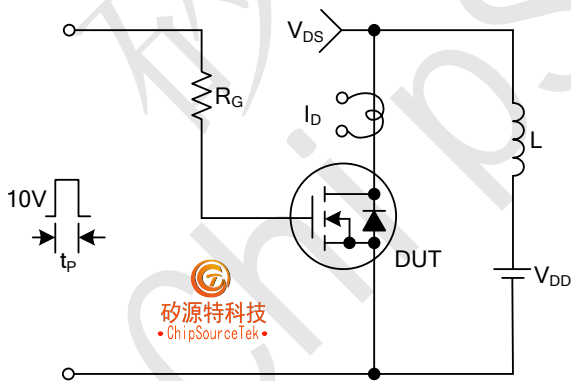

Unclamped Inductive Switching Test Circuit

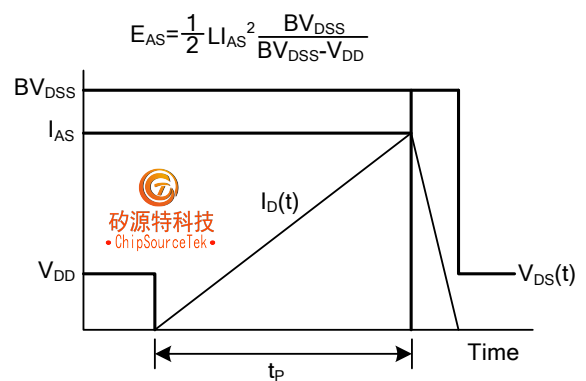

Unclamped Inductive Switching Waveforms



■ MOT5N50C/D TEST CIRCUITS AND WAVEFORMS(Cont.)

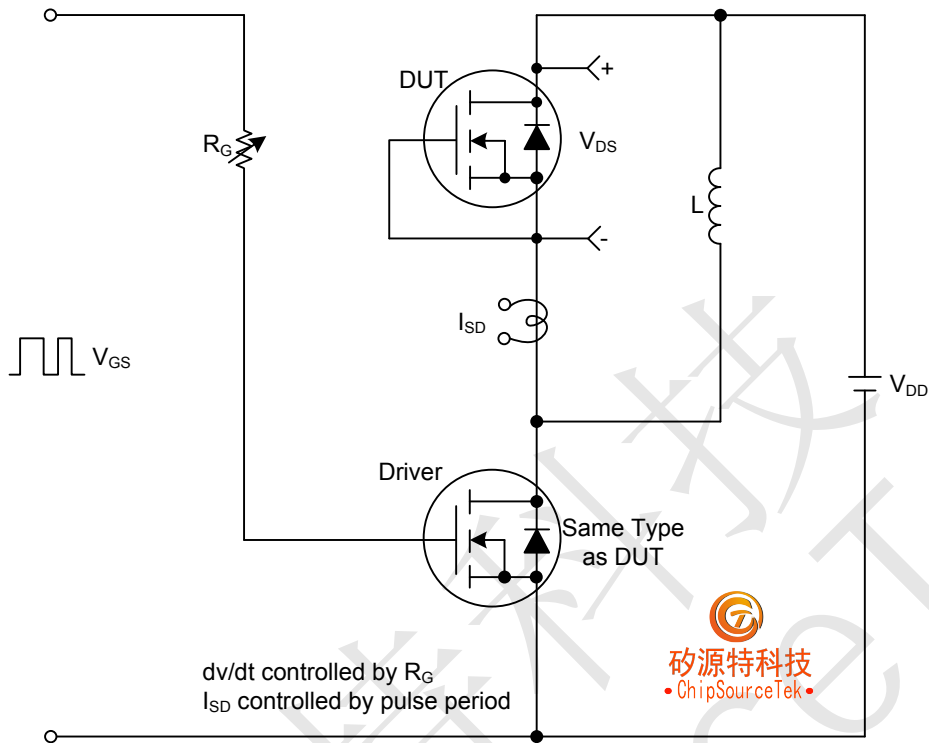

Peak Diode Recovery dv/dt Test Circuit & Waveforms

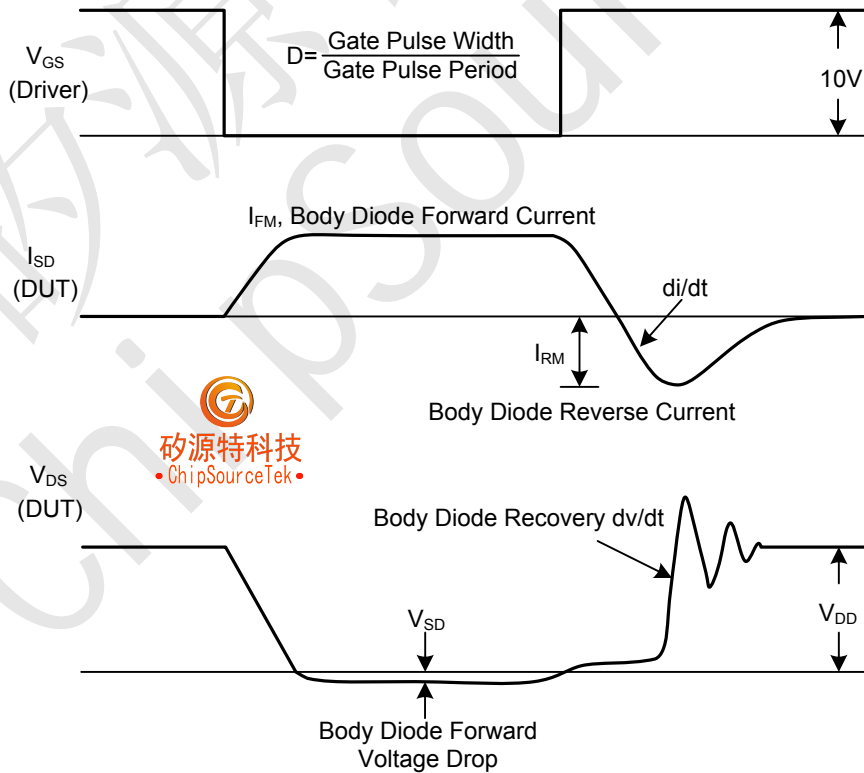



■ MOT5N50C/D TO-252-2L PACKAGE OUTLINE DIMENSIONS

