



P-Channel Enhancement Mode Field Effect Transistor

General Features		
V _{DS}	I _D	R _{DS(ON)} (m Ω) Typ
-30V	-55A	10 @ V _{GS} =-10.0V
		15 @ V _{GS} =-4.5V

DESCRIPTION

The MSH3509 uses advanced trench technology and design to provide excellent R_{DS(ON)} with low gate charge. It can be used in a wide variety of applications.

- High density cell design for ultra low Rdson
- Fully characterized avalanche voltage and current
- Good stability and uniformity with high E_{AS}
- Excellent package for good heat dissipation
- Special process technology for high ESD capability

APPLICATIONS

- Power Management in Note book
- Portable Equipment
- Battery Powered System
- Load Switch

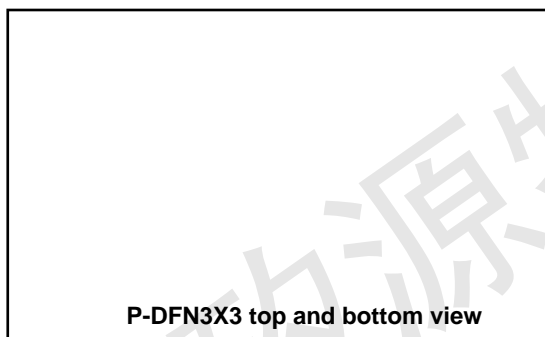

MSH3509
YYWW XX

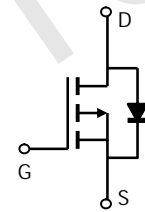

P-DFN3X3 top and bottom view
Marking and pin Assignment
Schematic diagram

Absolute Maximum Ratings T_A=25°C unless otherwise noted

Parameter	Symbol	Maximum	Units
Drain-Source Voltage	V _{DS}	-30	V
Gate-Source Voltage	V _{GS}	±20	V
Continuous Drain Current ^A	I _D	T _A =25°C	A
		T _A =70°C	
Pulsed Drain Current ^B	I _{DM}	-180	
Power Dissipation ^A	P _D	T _A =25°C	W
		T _A =70°C	
Junction and Storage Temperature Range	T _J , T _{STG}	-55 to 150	°C

Thermal Characteristics					
Parameter	Symbol	Typ	Max	Units	
Maximum Junction-to-Ambient ^A	R _{θJA}	45	62	°C/W	
Maximum Junction-to-Ambient ^A				Steady-State	54
Maximum Junction-to-Lead ^C	R _{θJL}	21	30	°C/W	



Electrical Characteristics ($T_J=25^\circ\text{C}$ unless otherwise noted)

Symbol	Parameter	Limit	Min	Typ	Max	Unit
STATIC						
BV_{DSS}	Drain-Source Breakdown Voltage	$V_{GS}=0, I_D=-250\ \mu\text{A}$	-30			V
$V_{GS(th)}$	Gate Threshold Voltage	$V_{DS}=V_{GS}, I_D=-250\ \mu\text{A}$	1		3	V
I_{GSS}	Gate Body Leakage	$V_{DS}=0V, V_{GS}=\pm 20V$			± 100	nA
I_{DSS}	Zero Gate Voltage Drain Current	$V_{DS}=-30V, V_{GS}=0V$			1	μA
$R_{DS(on)}$	Drain-Source On-Resistance	$V_{GS}=-10V, I_D=-30A$		10	12	m Ω
		$V_{GS}=-4.5V, I_D=-15A$		15	17	
V_{SD}	Diode Forward Voltage	$I_S=-2.7A, V_{GS}=0V$		0.7		V
DYNAMIC						
Q_g	Total Gate Charge	$V_{DS}=-15V, V_{GS}=-4.5V, I_D=-15A$		33		nC
Q_{gs}	Gate-Source Charge	$V_{DS}=-15V,$		11		
Q_{gd}	Gate-Drain Charge	$V_{GS}=-4.5V, I_D=-15A$		13		
C_{iss}	Input capacitance	$V_{DS}=-15V, V_{GS}=0V, f=1\text{MHz}$		3500		pF
C_{oss}	Output Capacitance			510		
C_{rss}	Reverse Transfer Capacitance			420		
$t_{d(on)}$	Turn-On Delay Time	$V_{DD}=-15V, R_L=15\ \Omega$ $I_D=-15A, V_{GEN}=-10V$ $R_G=3\ \Omega$		8		ns
t_r	Turn-On Rise Time			18		
$t_{d(off)}$	Turn-Off Delay Time			78		
t_f	Turn-Off Fall Time			42		

A: The value of $R_{\theta JA}$ is measured with the device mounted on 1in² FR-4 board with 2oz. Copper, in a still air environment with $\pm 25^\circ\text{C}$. The value in any given application depends on the user's specific board design. The current rating is based on the $t \leq 10s$ thermal resistance rating.

B: Repetitive rating, pulse width limited by junction temperature.

C. The $R_{\theta JA}$ is the sum of the thermal impedance from junction to lead $R_{\theta JL}$ and lead to ambient.

D. The static characteristics in Figures 1 to 6,12,14 are obtained using 80 μs pulses, duty cycle 0.5% max.

E. These tests are performed with the device mounted on 1 in² FR-4 board with 2oz. Copper, in a still air environment with $T_A=25^\circ\text{C}$. The SOA curve provides a single pulse rating.



Test Circuit

1) E_{AS} Test Circuits

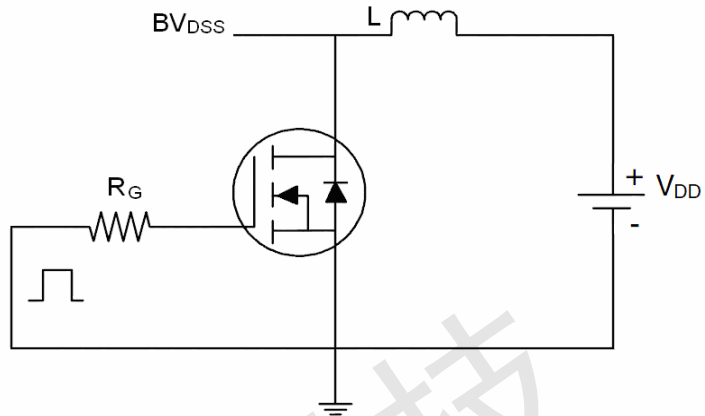

2) Gate Charge Test Circuit

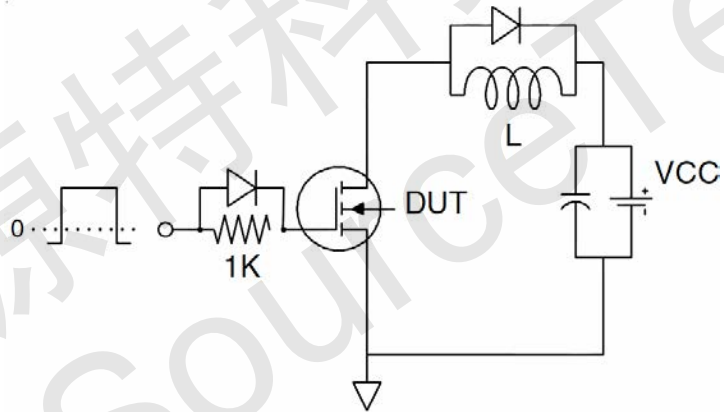

3) Switch Time Test Circuit

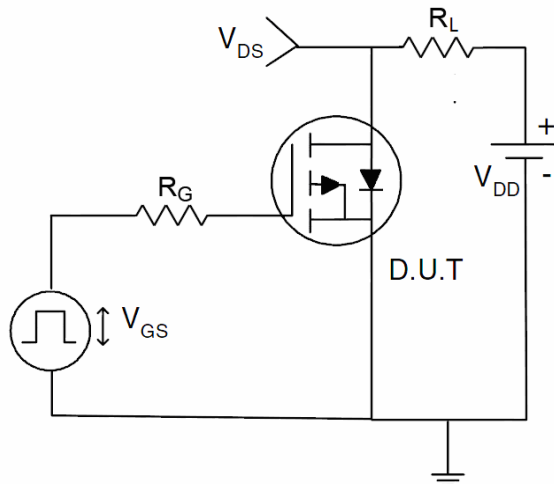



Typical Electrical and Thermal Characteristics (Curves)

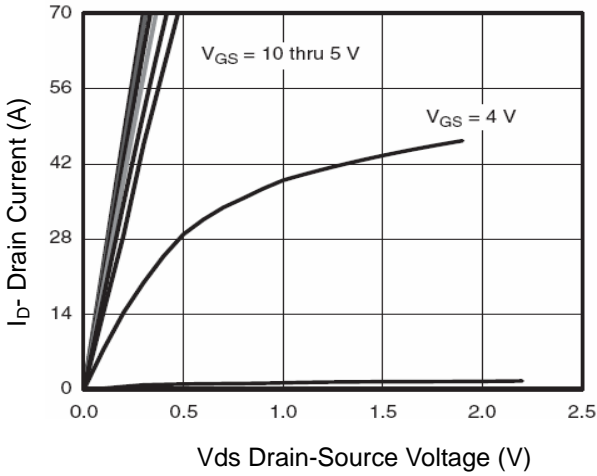

Figure 1 Output Characteristics

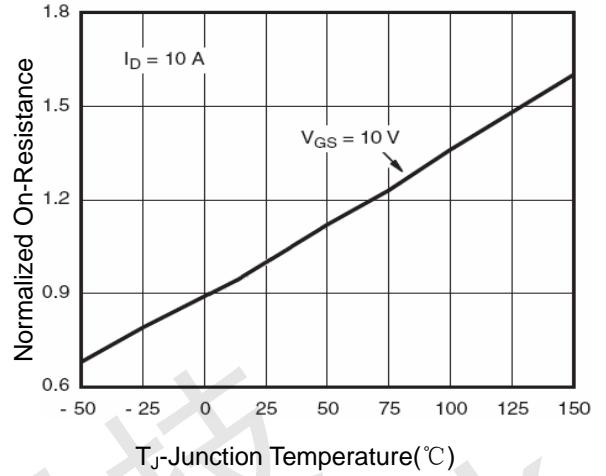

Figure 4 Rdson-Junction Temperature

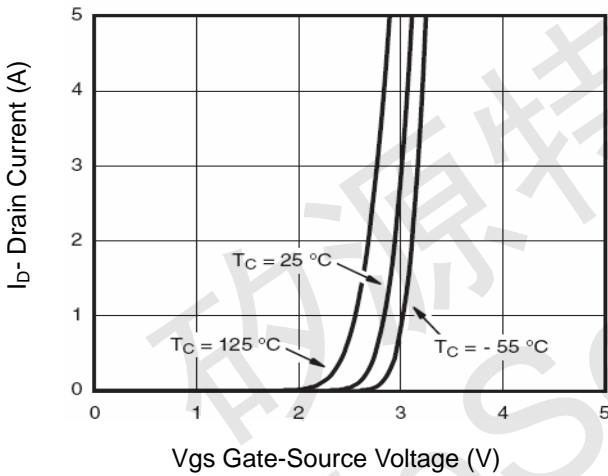

Figure 2 Transfer Characteristics

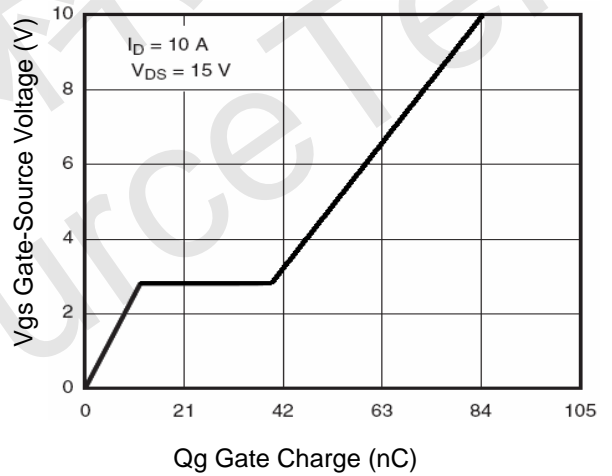

Figure 5 Gate Charge

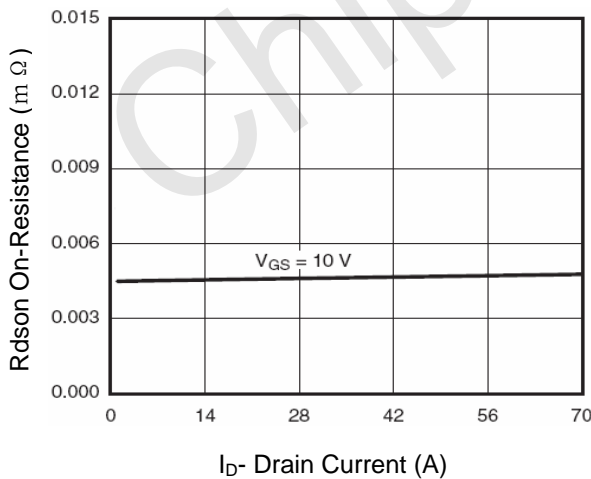

Figure 3 Rdson- Drain Current

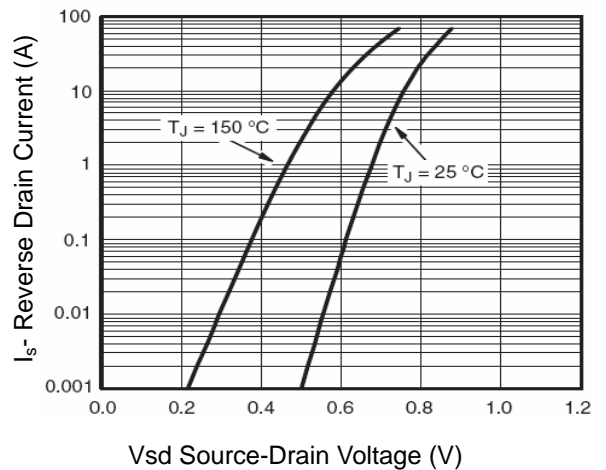
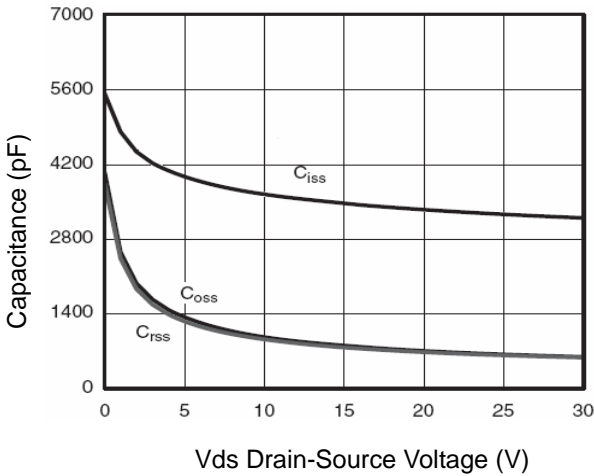
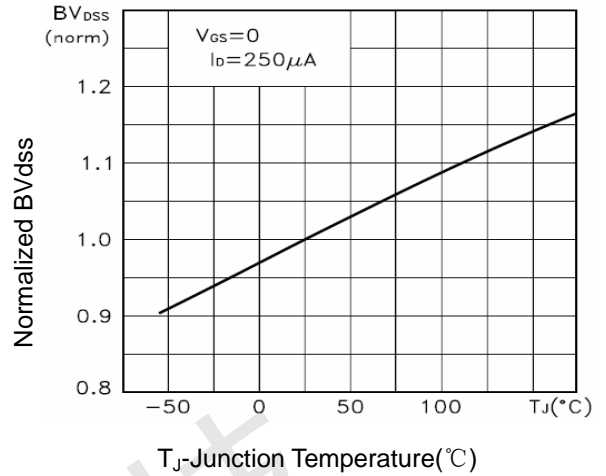

Figure 6 Source- Drain Diode Forward



Vds Drain-Source Voltage (V)
Figure 7 Capacitance vs Vds



T_J-Junction Temperature(°C)
Figure 9 BV_{DSS} vs Junction Temperature

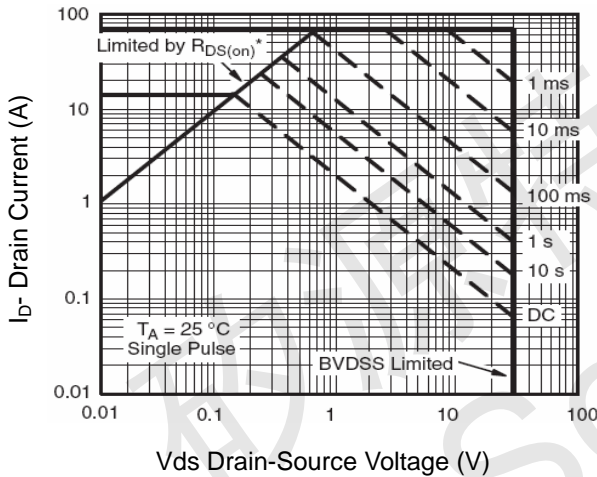

Vds Drain-Source Voltage (V)
Figure 8 Safe Operation Area

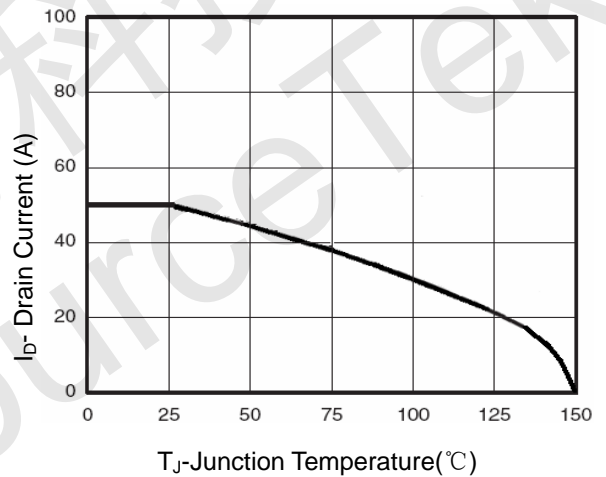

T_J-Junction Temperature(°C)
Figure 10 ID Current Derating vs Junction Temperature

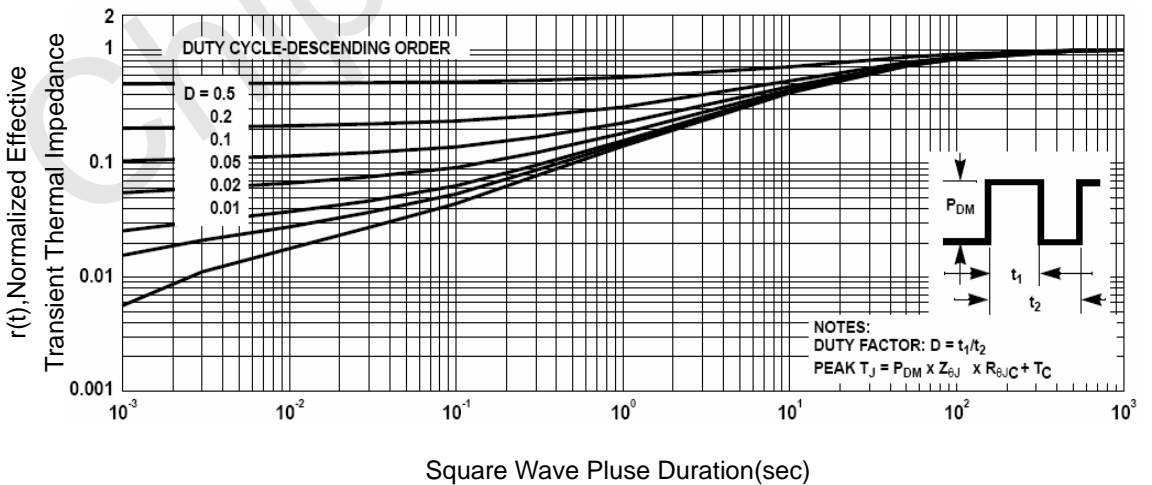

Square Wave Pulse Duration(sec)
Figure 11 Normalized Maximum Transient Thermal Impedance



PDFNWB(3×3)-8L PACKAGE OUTLINE DIMENSIONS

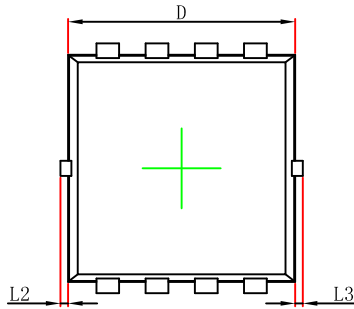

Top View
[顶视图]

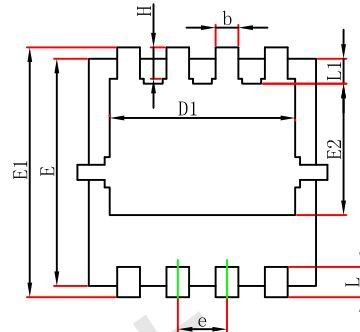

Bottom View
[背视图]

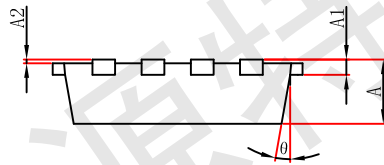

Side View
[侧视图]

Symbol	Dimensions In Millimeters		Dimensions In Inches	
	Min.	Max.	Min.	Max.
A	0.650	0.850	0.026	0.033
A1	0.152 REF.		0.006 REF.	
A2	0~0.05		0~0.002	
D	2.900	3.100	0.114	0.122
D1	2.300	2.600	0.091	0.102
E	2.900	3.100	0.114	0.122
E1	3.150	3.450	0.124	0.136
E2	1.535	1.935	0.060	0.076
b	0.200	0.400	0.008	0.016
e	0.550	0.750	0.022	0.030
L	0.300	0.500	0.012	0.020
L1	0.180	0.480	0.007	0.019
L2	0~0.100		0~0.004	
L3	0~0.100		0~0.004	
H	0.315	0.515	0.012	0.020
θ	9°	13°	9°	13°