



N-Channel Enhancement Mode Power MOSFET **MXD2060K**

DESCRIPTION

The MXD2060K uses advanced trench technology to provide excellent $R_{DS(ON)}$, low gate charge and operation with gate voltages as low as 2.5V. This device is suitable for use as a wide variety of applications.

GENERAL FEATURES

- $V_{DS}=20V$, $I_D=60A$
 $R_{DS(ON)}(Typ.)=6.2m\Omega$ @ $V_{GS}=2.5V$
 $R_{DS(ON)}(Typ.)=4.8m\Omega$ @ $V_{GS}=4.5V$
- High Power and current handling capability
- Lead free product is acquired
- Surface Mount Package

APPLICATION

- Battery Protection
- Load switch
- Power management

PINOUT

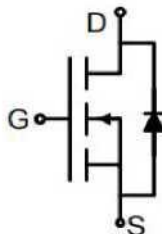

Schematic diagram

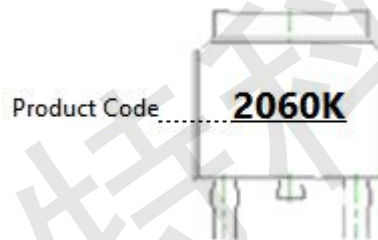

Marking and pin Assignment



TO-252 top view

ORDERING INFORMATION

Device	Marking	Storage Temperature	Package	Devices Per Reel
MXD2060K	2060K	-55°C to 150°C	TO-252	2500

KEY PERFORMANCE PARAMETERS ($T_A=25^\circ C$ unless otherwise noted)

Parameter	Symbol	Value	Unit
Drain-Source Voltage ($V_{GS}=0V$)	V_{DS}	20	V
Gate-Source Voltage ($V_{DS}=0V$)	V_{GS}	± 10	V
Drain Current-Continuous ($T_C=25^\circ C$) ^(Note 1)	I_D	60	A
Drain Current-Continuous ($T_C=100^\circ C$)	I_D	42.5	A
Drain Current-Continuous@Current-Pulsed ^(Note 2)	$I_{DM(pluse)}$	240	A
Maximum Power Dissipation ($T_C=25^\circ C$)	P_D	50	W
Maximum Power Dissipation ($T_C=100^\circ C$)	P_D	25	W
Avalanche energy ^(Note3)	E_{AS}	156	mJ
Operating Junction and Storage Temperature Range	T_J, T_{STG}	-55 to 175	$^\circ C$

THERMAL CHARACTERISTIC

Parameter	Symbol	Value	Unit
Thermal Resistance, Junction-to-Case	$R_{\theta JC}$	3	$^\circ C/W$

Notes 1. The maximum current rating is package limited.

Notes 2. Repetitive Rating: Pulse width limited by maximum junction temperature

Notes 3. EAS condition: $T_J=25^\circ C$, $V_{DD}=30V$, $V_G=4.5V$, $R_G=25\Omega$,



N-Channel Enhancement Mode Power MOSFET **MXD2060K**



ELECTRICAL CHARACTERISTICS ($T_A=25^\circ\text{C}$ unless otherwise noted)

Parameter	Symbol	Condition	Min	Typ	Max	Unit
-----------	--------	-----------	-----	-----	-----	------

On/Off Characteristics

Drain-Source Breakdown Voltage	BV_{DSS}	$V_{GS}=0V, I_D=250\mu A$	19.5	22	-	V
Zero Gate Voltage Drain Current	I_{DSS}	$V_{DS}=19V, V_{GS}=0V$	-	-	1	μA
Gate-Body Leakage Current	I_{GSS}	$V_{GS}=\pm 10V, V_{DS}=0V$	-	-	± 100	nA
Gate Threshold Voltage	$V_{GS(th)}$	$V_{DS}=V_{GS}, I_D=250\mu A$	0.5	0.7	1.1	V
Forward Transconductance	g_{FS}	$V_{DS}=5V, I_D=10A$	-	38	-	S
Drain-Source On-State Resistance	$R_{DS(ON)}$	$V_{GS}=2.5V, I_D=10A$	-	6.2	9.4	$m\Omega$
		$V_{GS}=4.5V, I_D=15A$	-	4.8	6.3	$m\Omega$

Dynamic Characteristics

Input Capacitance	C_{iss}	$V_{DS}=10V, V_{GS}=0V,$ $F=1.0MHz$	-	1825	-	pF
Output Capacitance	C_{oss}		-	275	-	pF
Reverse Transfer Capacitance	C_{rss}		-	218	-	pF
Gate resistance	R_g	$V_{DS}=0V, V_{GS}=0V,$ $F=1.0MHz$	-	1.3	-	Ω

Switching Times

Turn-on Delay Time	$t_{d(on)}$	$V_{GS}=4.5V, V_{DS}=10V,$ $R_L=0.5\Omega, R_{GEN}=3\Omega$	-	5.9	-	nS
Turn-on Rise Time	t_r		-	10.2	-	nS
Turn-Off Delay Time	$t_{d(off)}$		-	54	-	nS
Turn-Off Fall Time	t_f		-	16	-	nS
Total Gate Charge	Q_g	$V_{DS}=10V, I_D=20A,$ $V_{GS}=4.5V$	-	25.3	-	nC
Gate-Source Charge	Q_{gs}		-	2.6	-	nC
Gate-Drain Charge	Q_{gd}		-	9.4	-	nC

Source-Drain Diode Characteristics

Source-Drain Current(Body Diode)	I_{SD}		-	-	60	A
Forward On Voltage	V_{SD}	$V_{GS}=0V, I_S=1A$	-	0.78	1.2	V
Body Diode Reverse Recovery Time	t_{rr}	$I_F=20A, di/dt=100A/\mu s$	-	26.5	-	nS
Body Diode Reverse Recovery Charge	Q_{rr}	$I_F=20A, di/dt=100A/\mu s$	-	25	-	nC



N-Channel Enhancement Mode Power MOSFET **MXD2060K**

TEST CIRCUIT

1) EAS Test Circuits

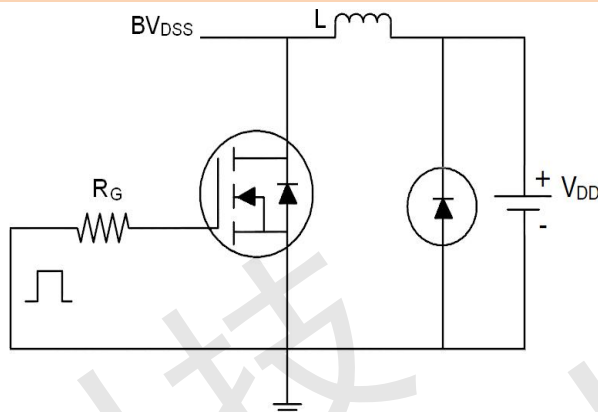
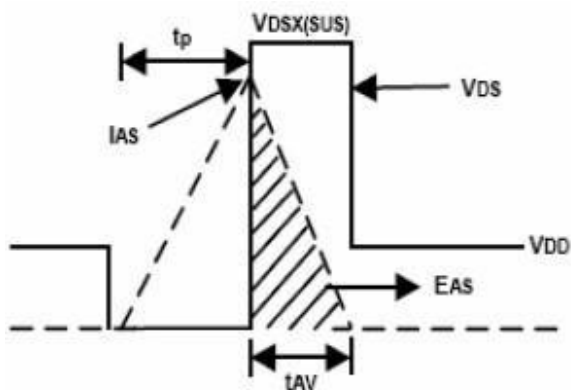

2) Gate Charge Test Circuit

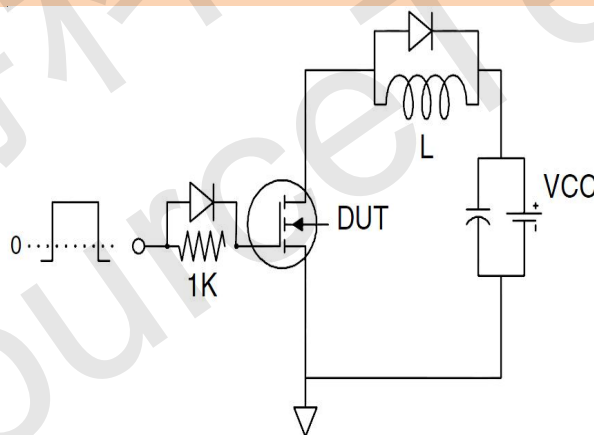
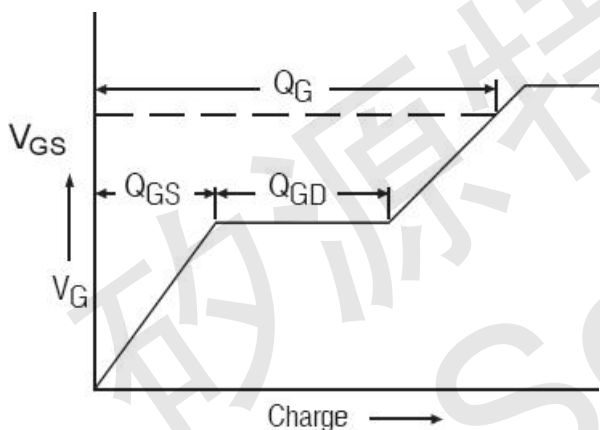

3) Switch Time Test Circuit

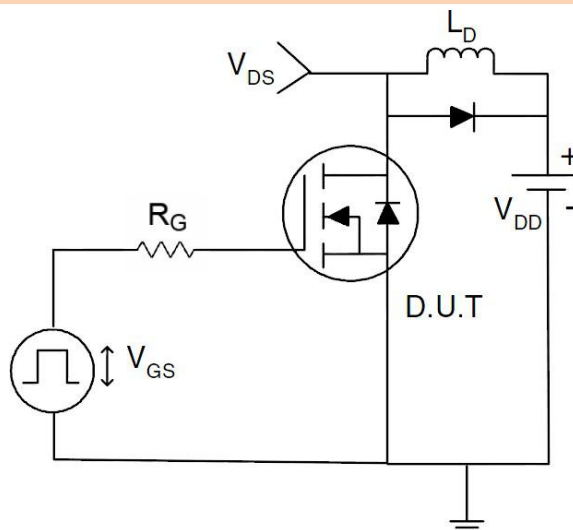
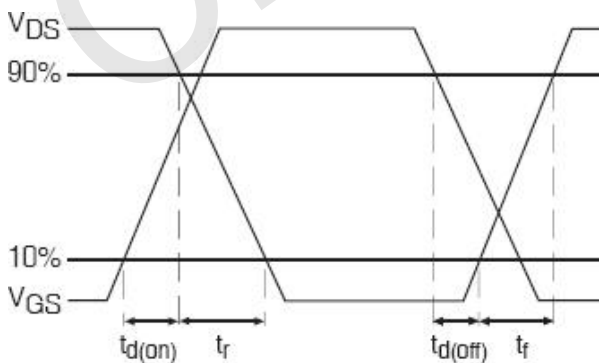



N-Channel Enhancement Mode Power MOSFET **MXD2060K**

TYPICAL PERFORMANCE CHARACTERISTICS

Figure1. Output Characteristics

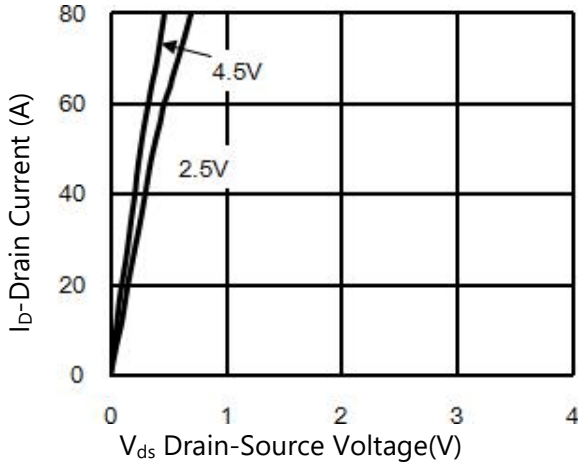

Figure2. Transfer Characteristics

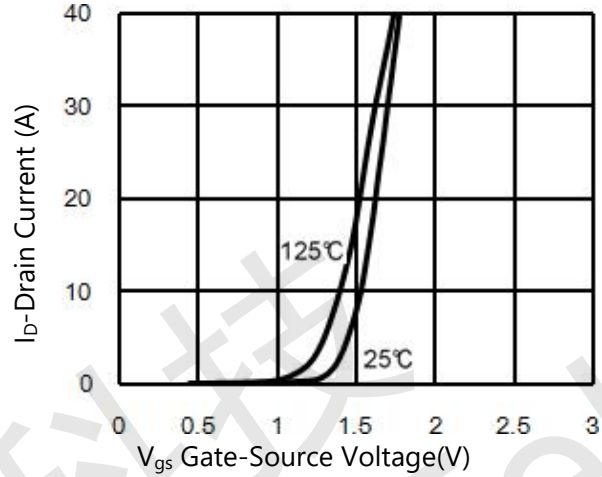

Figure3. Power Dissipation

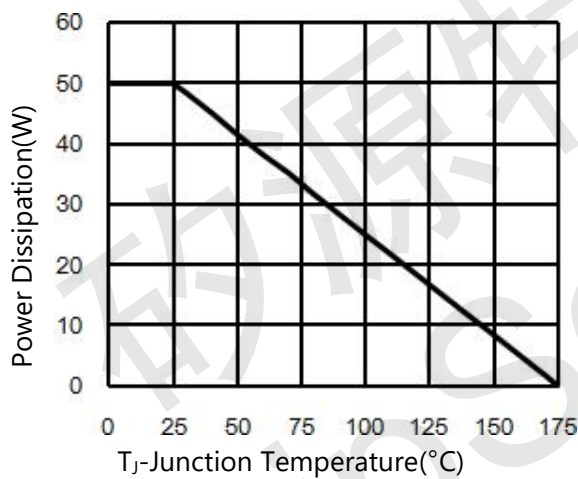

Figure4. Drain Current

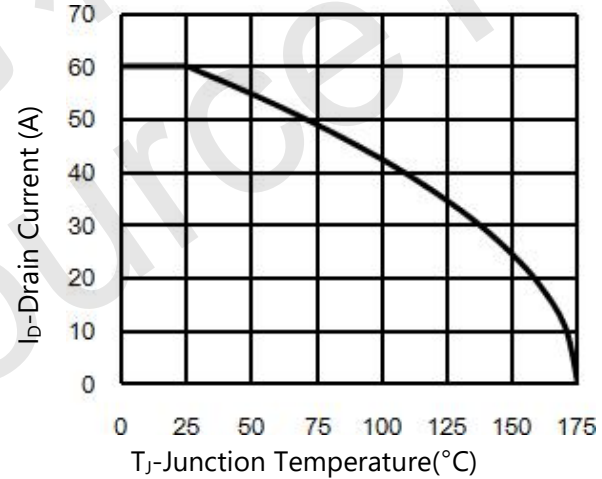

Figure5. $V_{GS(th)}$ vs Junction Temperature

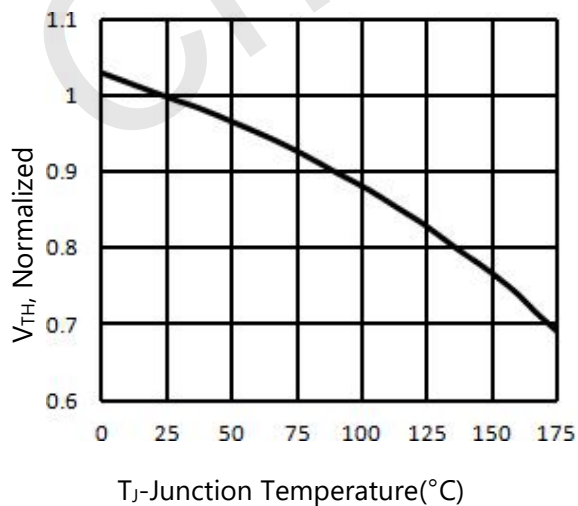
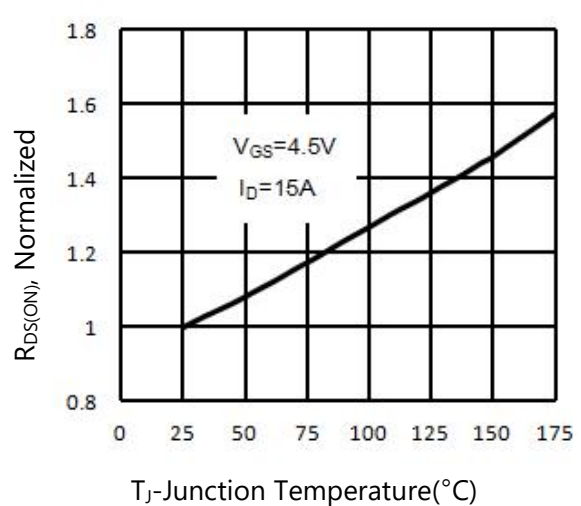

Figure6. $R_{DS(on)}$ vs Junction Temperature





N-Channel Enhancement Mode Power MOSFET **MXD2060K**

TYPICAL PERFORMANCE CHARACTERISTICS

Figure7. Gate Charge Waveforms

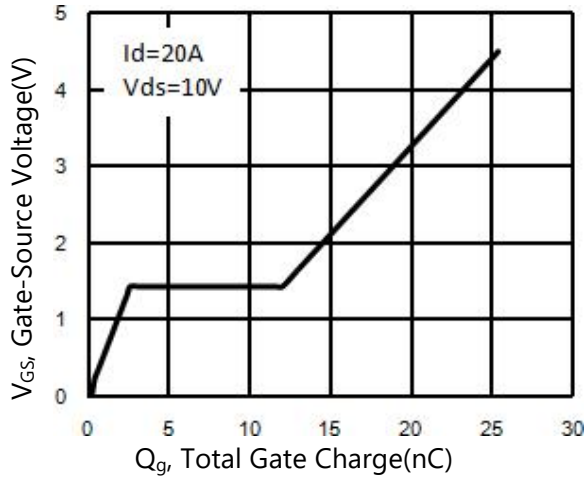

Figure8. Capacitance

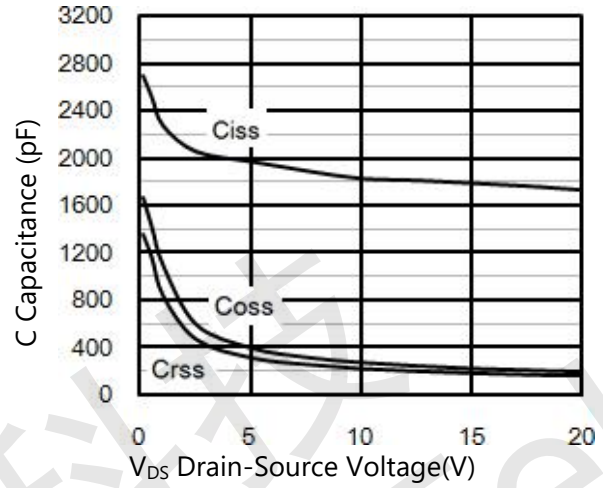

Figure9. Body-Diode Characteristics

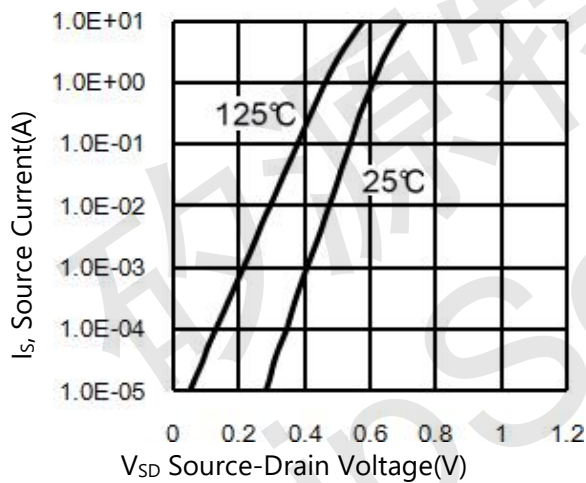
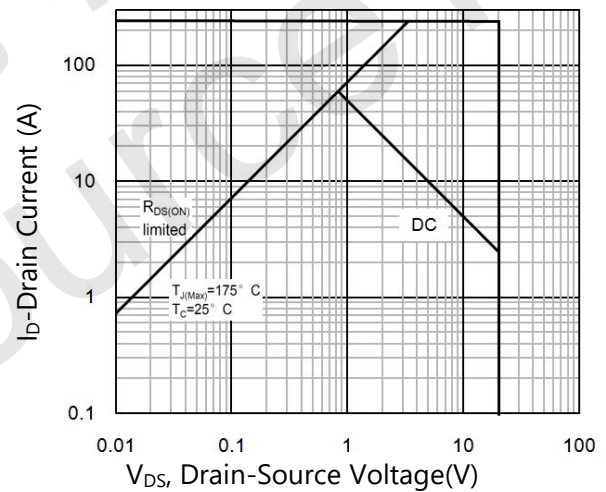

Figure10. Maximum Safe Operating Area





N-Channel Enhancement Mode Power MOSFET **MXD2060K**

PACKAGE INFORMATION

TO-252

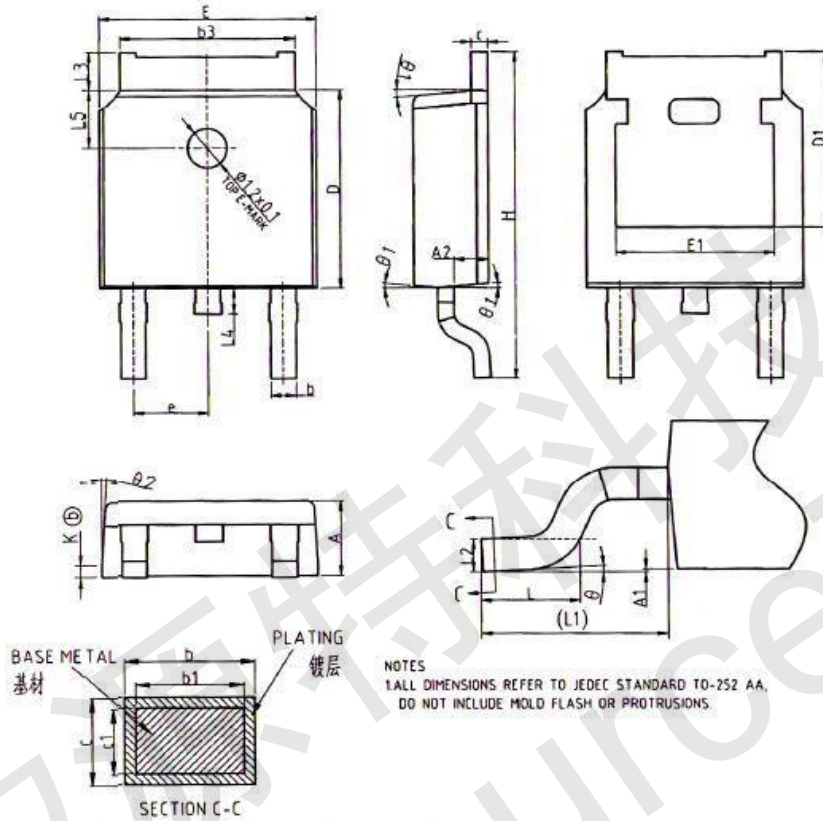

SYMBOL	Dimensions In Millimeters		
	MIN	NOM	MAX
A	2.20	2.30	2.38
A1	0.00	-	0.10
A2	0.97	1.07	1.17
b	0.72	0.78	0.85
b1	0.71	0.76	0.81
b3	5.23	5.33	5.46
c	0.47	0.53	0.58
c1	0.46	0.51	0.56
D	6.00	6.10	6.20
D1		5.30REF	
E	6.50	6.60	6.70
E1	4.70	4.83	4.92
e		2.286BSC	
H	9.90	10.10	10.30
L	1.40	1.50	1.70
L1		2.90REF	
L2		0.51BSC	
L3	0.90	-	1.25
L4	0.60	0.80	1.00
L5	1.70	1.80	1.90
θ	0°	-	8°
θ1	5°	7°	9°
θ2	5°	7°	9°
K		0.40REF	