



PES230N10K N-Channel Enhancement Mode Power MOSFET

PES230N10K Description

The PES230N10K uses deep trench technology to provide excellent $R_{DS(ON)}$ and low gate charge. It can be used in a wide variety of applications.

PES230N10K General Features

- $V_{DS} = 100V$, $I_D = 50A$
- $R_{DS(ON)} < 23m\Omega @ V_{GS}=10V$
- $R_{DS(ON)} < 33m\Omega @ V_{GS}=4.5V$
- High Power and current handing capability
- Lead free product is acquired
- Surface Mount Package

PES230N10K Application

- High Frequency Switching
- Synchronous Rectification

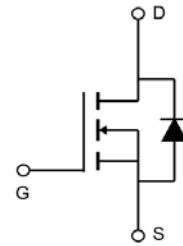

Schematic diagram

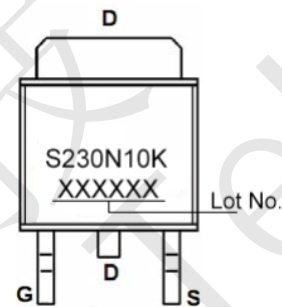

Marking and pin assignment

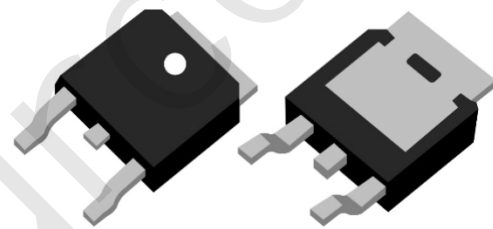

TO-252-2L

PES230N10K Absolute Maximum Ratings (TC=25°C unless otherwise noted)

Parameter	Symbol	Rating	Unit
Drain-Source Voltage	V_{DS}	100	V
Gate-Source Voltage	V_{GS}	± 20	V
Drain Current-Continuous	I_D	50	A
Drain Current-Continuous (TC=100°C)	$I_D(TC=100^\circ C)$	34	A
Pulsed Drain Current (Note 1)	I_{DM}	150	A
Maximum Power Dissipation	P_D	115	W
Single Pulse Avalanche Energy (L=0.5mH)	E_{AS}	16	mJ
Operating Junction and Storage Temperature Range	T_J, T_{STG}	-55 To 175	°C

PES230N10K Thermal Characteristic

Thermal Resistance, Junction-to-Case (Note 2)	$R_{\theta JC}$	1.3	°C/W
Thermal Resistance, Junction-to-Ambient (Note 2)	$R_{\theta JA}$	75	°C/W



PES230N10K N-Channel Enhancement Mode Power MOSFET

PES230N10K Electrical Characteristics (TC=25°C unless otherwise noted)

Parameter	Symbol	Condition	Min	Typ	Max	Unit
Off Characteristics						
Drain-Source Breakdown Voltage	BV_{DSS}	$V_{GS}=0V, I_D=250\mu A$	100	-	-	V
Zero Gate Voltage Drain Current	I_{DSS}	$V_{DS}=80V, V_{GS}=0V$	-	-	1	μA
Gate-Body Leakage Current	I_{GSS}	$V_{GS}=\pm 20V, V_{DS}=0V$	-	-	± 100	nA
On Characteristics (Note 3)						
Gate Threshold Voltage	$V_{GS(th)}$	$V_{DS}=V_{GS}, I_D=250\mu A$	0.8	1.2	1.6	V
Drain-Source On-State Resistance	$R_{DS(on)}$	$V_{GS}=10V, I_D=20A$	-	19.5	23	m Ω
		$V_{GS}=4.5V, I_D=10A$	-	23	33	m Ω
Forward Transconductance	g_{FS}	$V_{DS}=10V, I_D=20A$	-	22	-	S
Dynamic Characteristics (Note 4)						
Input Capacitance	C_{iss}	$V_{DS}=50V, V_{GS}=0V,$ $F=1.0MHz$	-	822	-	pF
Output Capacitance	C_{oss}		-	310	-	pF
Reverse Transfer Capacitance (Note 4)	C_{rss}		-	23.5	-	pF
Gate Resistance	R_g	$V_{DS}=V_{GS}=0V, F=1.0MHz$	-	1.6	-	Ω
Switching Characteristics						
Turn-on Delay Time	$t_{d(on)}$	$V_{DS}=50V, V_{GS}=10V,$ $R_G=3\Omega, I_D=20A$	-	15	-	nS
Turn-on Rise Time	t_r		-	3.2	-	nS
Turn-Off Delay Time	$t_{d(off)}$		-	30	-	nS
Turn-Off Fall Time	t_f		-	7.6	-	nS
Total Gate Charge	Q_g	$V_{DS}=50V, I_D=20A,$ $V_{GS}=10V$	-	22.7	-	nC
Gate-Source Charge	Q_{gs}		-	6.2	-	nC
Gate-Drain Charge	Q_{gd}		-	5.3	-	nC
Drain-Source Diode Characteristics						
Maximum Body-Diode Continuous Current	I_S		-	-	50	A
Diode Forward Voltage (Note 3)	V_{SD}	$V_{GS}=0V, I_S=20A$	-	-	1.2	V
Body Diode Reverse Recovery Time	t_{rr}	$I_F=20A, dI/dt=100A/\mu s$	-	34	-	ns
Body Diode Reverse Recovery Charge	Q_{rr}		-	31	-	nC

Notes:

1. Repetitive Rating: Pulse width limited by maximum junction temperature.
2. Surface Mounted on FR4 Board, $t \leq 10$ sec.
3. Pulse Test: Pulse Width $\leq 300\mu s$, Duty Cycle $\leq 2\%$.
4. Guaranteed by design, not subject to product.



PES230N10K Typical Electrical and Thermal Characteristics

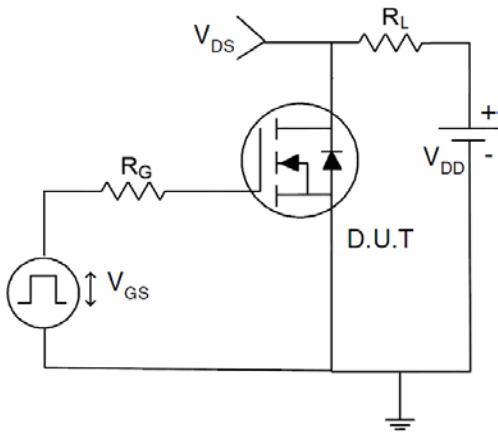

Figure 1 Switching Test Circuit

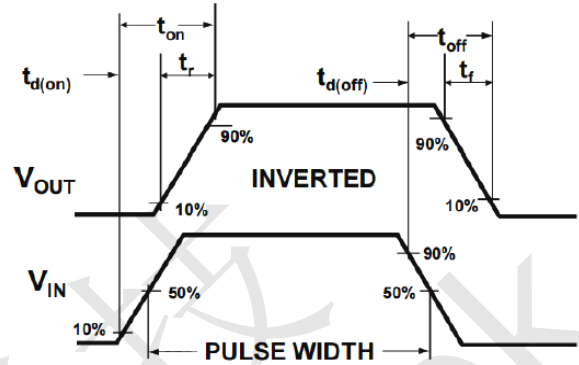

Figure 2 Switching Waveform

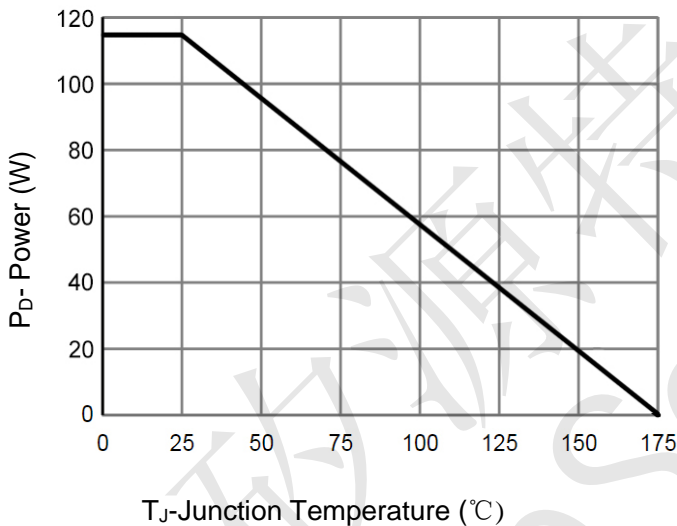

Figure 3 Power De-rating

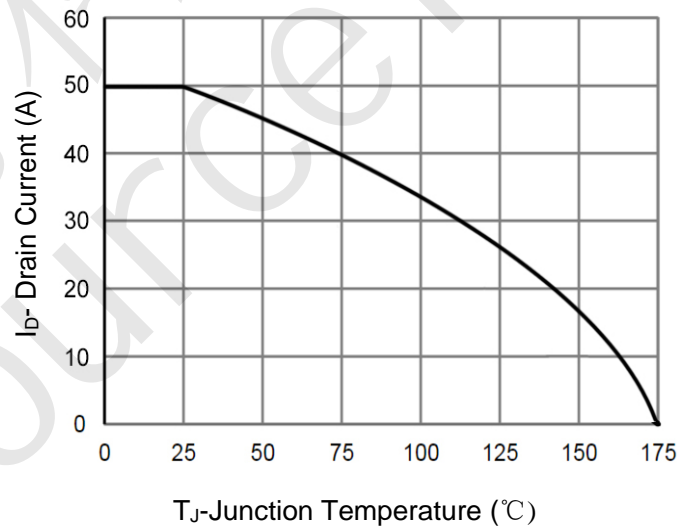

Figure 4 Drain Current

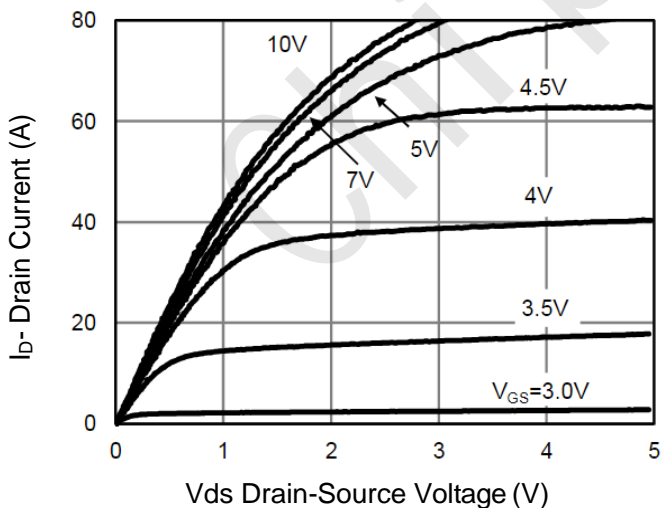

Figure 5 Output Characteristics

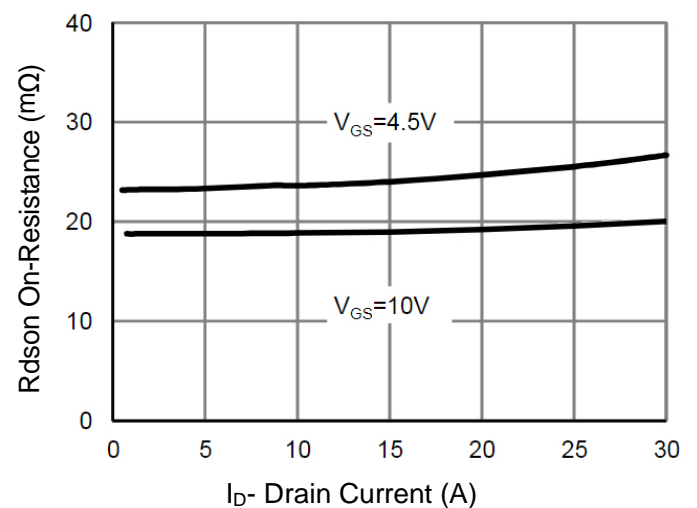

Figure 6 Rdson vs Drain Current



PES230N10K N-Channel Enhancement Mode Power MOSFET

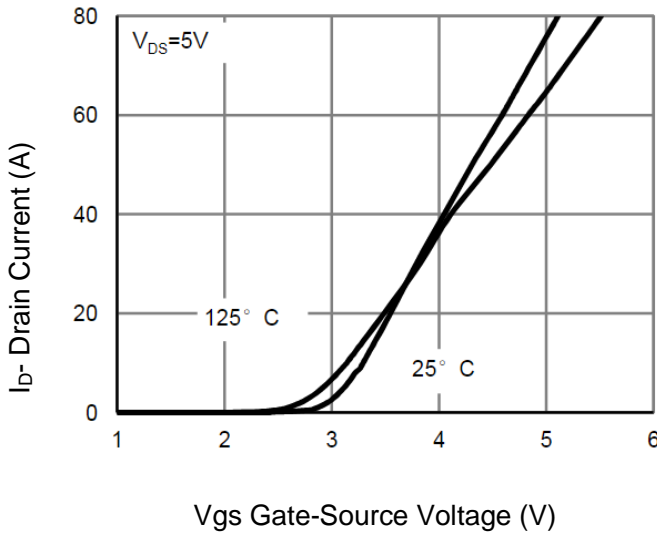

Figure 7 Transfer Characteristics

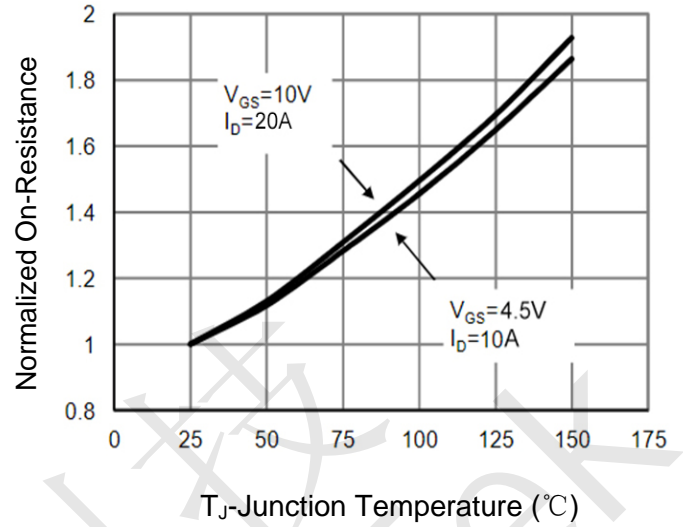

Figure 8 Rdson vs Junction Temperature

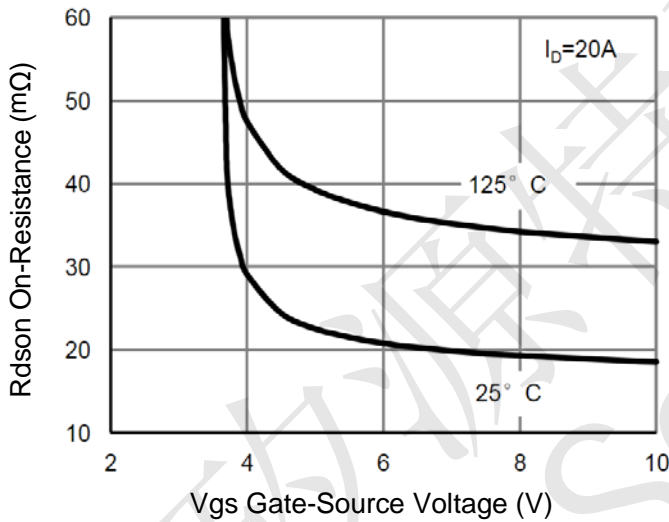

Figure 9 Rdson vs Vgs

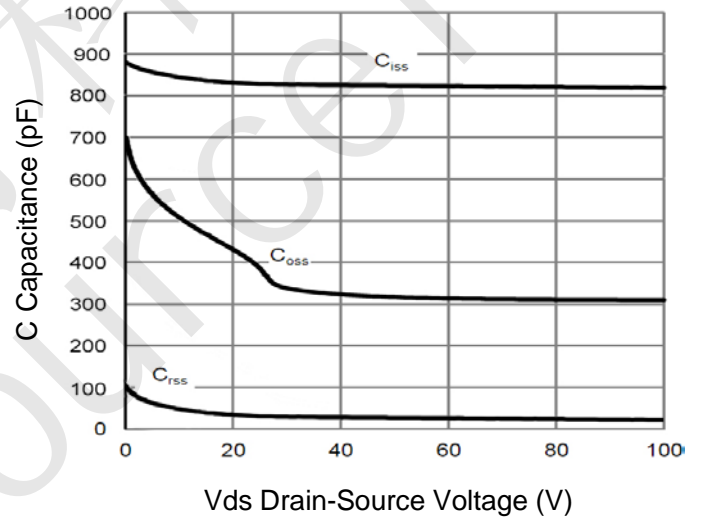

Figure 10 Capacitance vs Vds

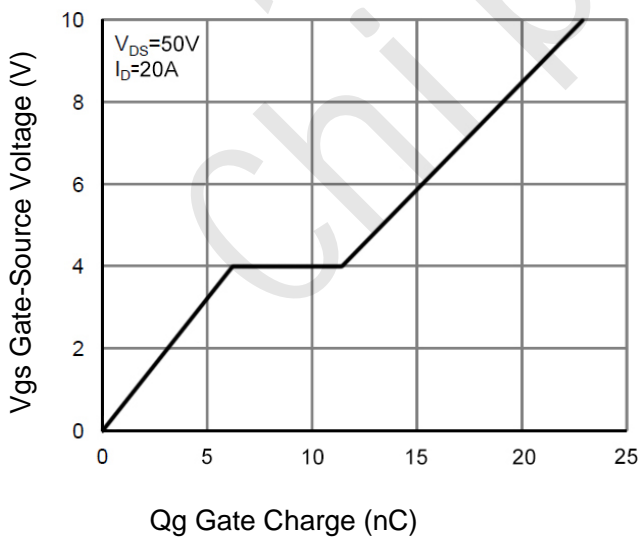

Figure 11 Gate Charge

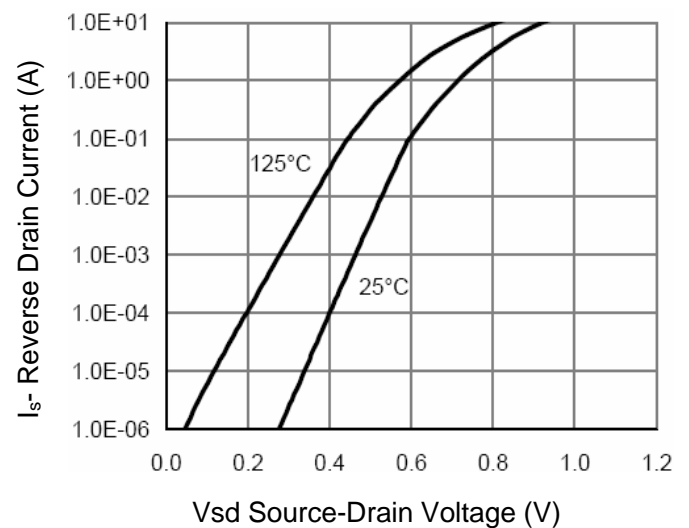

Figure 12 Source- Drain Diode Forward



PES230N10K N-Channel Enhancement Mode Power MOSFET

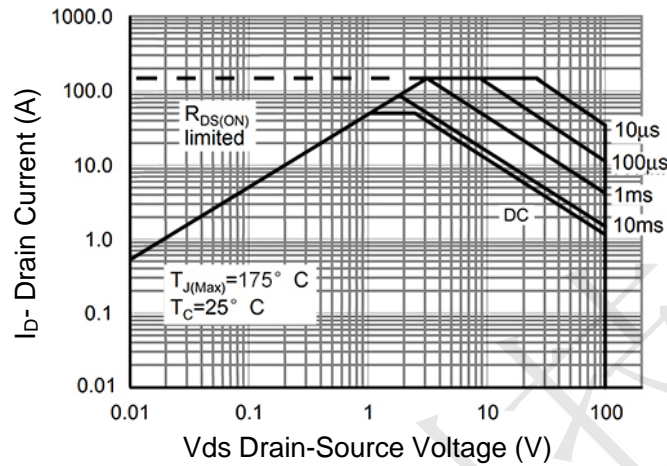

Figure 13 Safe Operation Area

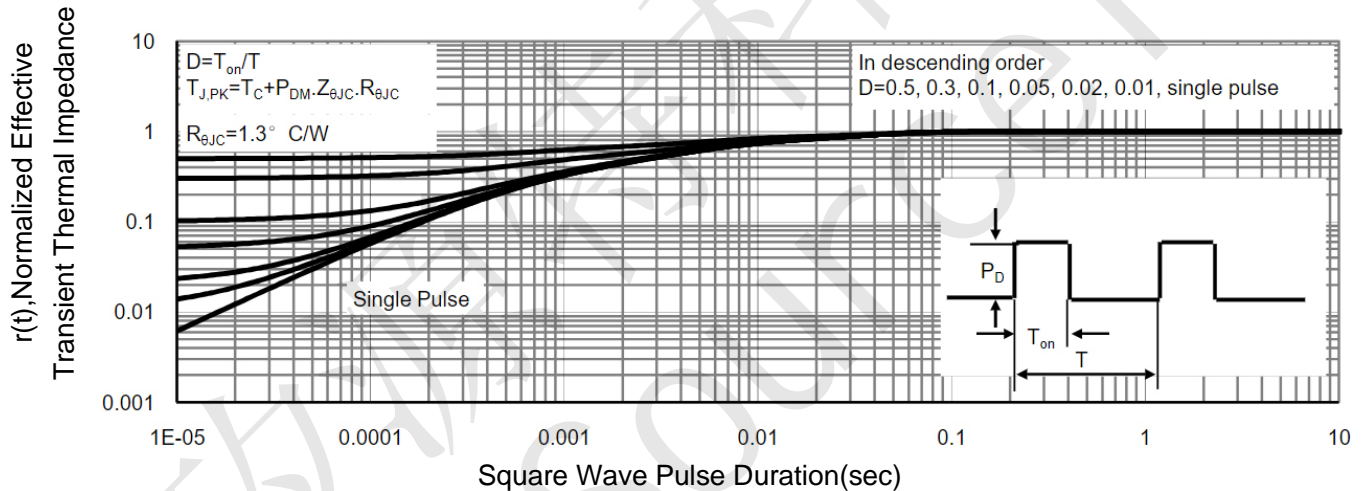
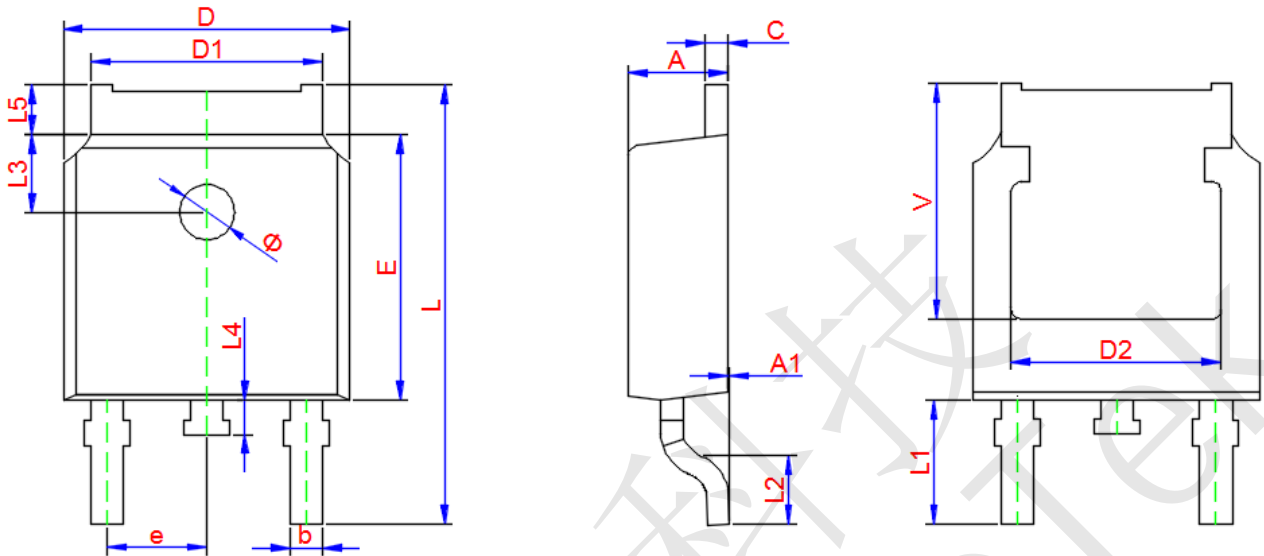

Figure 14 Normalized Maximum Transient Thermal Impedance



TO-252-2L Package Information



Symbol	Dimensions In Millimeters		
	Min.	Typ.	Max.
A	2.200	2.300	2.400
A1	0.000	--	0.127
b	0.660	0.760	0.860
D	6.500	6.600	6.700
D1	5.100	5.330	5.460
C	0.450	0.500	0.600
D2	4.830 TYP.		
E	6.000	6.100	6.200
e	2.186	2.286	2.386
L	9.800	10.100	10.400
L1	2.900 TYP.		
L2	1.400	1.500	1.600
L3	1.800 TYP.		
L4	0.600	0.800	1.000
L5	0.900	--	1.250
Φ	1.100.	--	1.300
θ	0°	--	8°
V	5.350		