



40V/200A N-Channel Advanced Power MOSFET

VS40200ATD

Features

- N-Channel, 5V Logic Level Control
- Enhancement mode
- Very low on-resistance $R_{DS(on)}$ @ $V_{GS}=4.5V$
- 100% Avalanche test
- Pb-free lead plating; RoHS compliant

V_{DS}	40	V
$R_{DS(on),TYP} @ V_{GS}=10V$	2.3	mΩ
$R_{DS(on),TYP} @ V_{GS}=4.5V$	3.3	mΩ
I_D	200	A

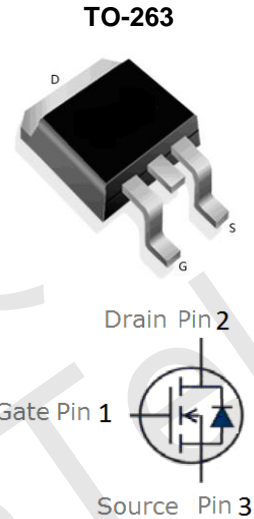

Part ID	Package Type	Marking	Tape and reel information
VS40200ATD	TO-263	40200ATD	1000pcs/Reel

Maximum ratings, at $T_j=25^{\circ}C$, unless otherwise specified

Symbol	Parameter	Rating	Unit
$V_{(BR)DSS}$	Drain-Source breakdown voltage	40	V
I_S	Diode continuous forward current	$T_C=25^{\circ}C$ 200	A
I_D	Continuous drain current @ $V_{GS}=-10V$	$T_C=25^{\circ}C$ 200	A
		$T_C=100^{\circ}C$ 142	A
I_{DM}	Pulse drain current tested ①	$T_C=25^{\circ}C$ 800	A
EAS	Avalanche energy, single pulsed ②	390	mJ
P_D	Maximum power dissipation	$T_C=25^{\circ}C$ 150	W
V_{GS}	Gate-Source voltage	± 20	V
$T_{STG} T_J$	Storage and operating temperature range	-55 to 175	$^{\circ}C$
Thermal Characteristics			
$R_{\theta JC}$	Thermal Resistance-Junction to Case	1.0	$^{\circ}C/W$
$R_{\theta JA}$	Thermal Resistance-Junction to Ambient	62.5	$^{\circ}C/W$



40V/200A N-Channel Advanced Power MOSFET

VS40200ATD

Symbol	Parameter	Condition	Min.	Typ.	Max.	Unit
Static Electrical Characteristics @ $T_j = 25^\circ\text{C}$ (unless otherwise stated)						
$V_{(BR)DSS}$	Drain-Source Breakdown Voltage	$V_{GS}=0V, I_D=250\mu A$	40	--	--	V
I_{DSS}	Zero Gate Voltage Drain Current	$V_{DS}=40V, V_{GS}=0V$	--	--	1	μA
	Zero Gate Voltage Drain Current($T_j=125^\circ\text{C}$)	$V_{DS}=40V, V_{GS}=0V$	--	--	100	μA
I_{GSS}	Gate-Body Leakage Current	$V_{GS}=\pm 20V, V_{DS}=0V$	--	--	± 100	nA
$V_{GS(TH)}$	Gate Threshold Voltage	$V_{DS}=V_{GS}, I_D=250\mu A$	1.2	1.8	2.4	V
$R_{DS(ON)}$	Drain-Source On-State Resistance ^③	$V_{GS}=10V, I_D=60A$	--	2.3	4	m Ω
$R_{DS(ON)}$	Drain-Source On-State Resistance ^③	$V_{GS}=4.5V, I_D=30A$	--	3.3	6	m Ω
Dynamic Electrical Characteristics @ $T_j = 25^\circ\text{C}$ (unless otherwise stated)						
C_{iss}	Input Capacitance	$V_{DS}=20V, V_{GS}=0V, f=1\text{MHz}$	5600	6605	7600	pF
C_{oss}	Output Capacitance		400	550	700	pF
C_{rss}	Reverse Transfer Capacitance		320	440	560	pF
R_g	Gate Resistance	$f=1\text{MHz}$	--	1.9	--	Ω
Q_g	Total Gate Charge	$V_{DS}=20V, I_D=30A, V_{GS}=10V$	--	109	--	nC
Q_{gs}	Gate-Source Charge		--	30.5	--	nC
Q_{gd}	Gate-Drain Charge		--	42	--	nC
Switching Characteristics						
$t_{d(on)}$	Turn-on Delay Time	$V_{DD}=20V, I_D=30A, R_G=3\Omega, V_{GS}=10V$	--	30	--	nS
t_r	Turn-on Rise Time		--	24	--	nS
$t_{d(off)}$	Turn-Off Delay Time		--	45.5	--	nS
t_f	Turn-Off Fall Time		--	16.5	--	nS
Source- Drain Diode Characteristics @ $T_j = 25^\circ\text{C}$ (unless otherwise stated)						
V_{SD}	Forward on voltage	$I_{SD}=30A, V_{GS}=0V$	--	0.9	1.2	V
t_{rr}	Reverse Recovery Time	$T_j=25^\circ\text{C}, I_{sd}=30A, V_{GS}=0V, di/dt=500A/\mu s$	--	29	--	nS
Q_{rr}	Reverse Recovery Charge		179	--	--	nC

NOTE:

- ① Repetitive rating; pulse width limited by max. junction temperature.
- ② Limited by T_{jmax} , starting $T_j = 25^\circ\text{C}$, $L = 0.5\text{mH}, R_G = 25\Omega, I_{AS} = 29A, V_{GS} = 10V$. Part not recommended for use above this value
- ③ Pulse width $\leq 300\mu s$; duty cycle $\leq 2\%$.



Typical Characteristics

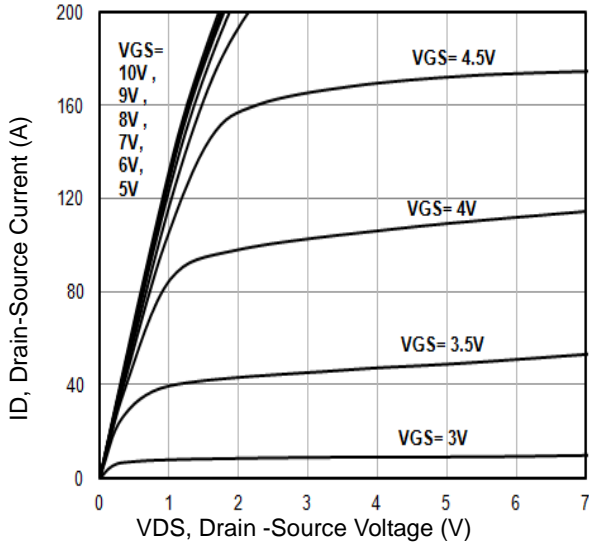

Fig1. Typical Output Characteristics

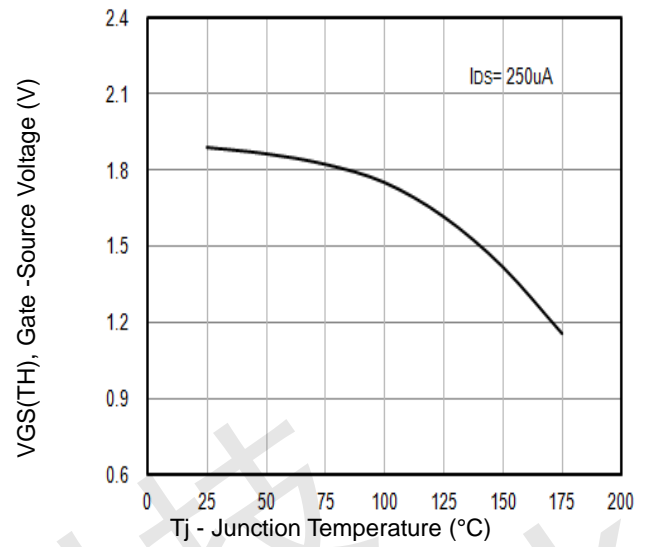

Fig2. $V_{GS(TH)}$ Gate-Source Voltage Vs. T_j

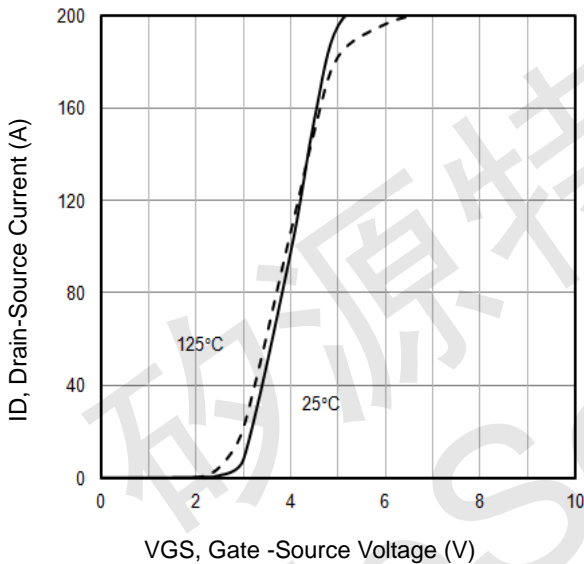

Fig3. Typical Transfer Characteristics

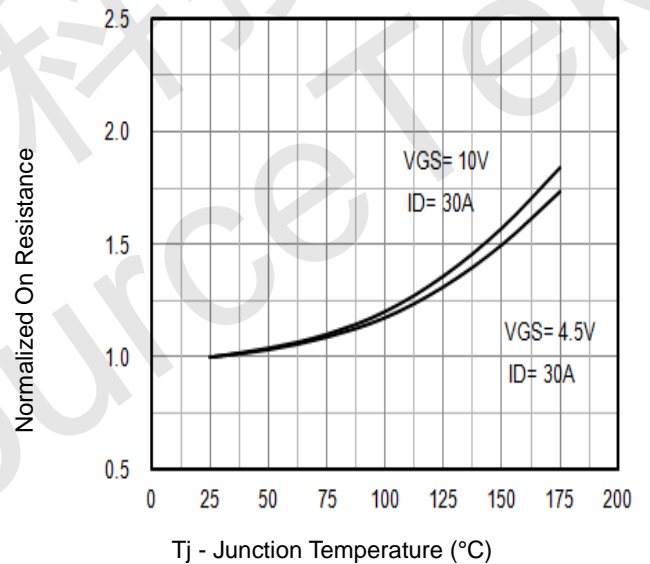

Fig4. Normalized On-Resistance Vs. T_j

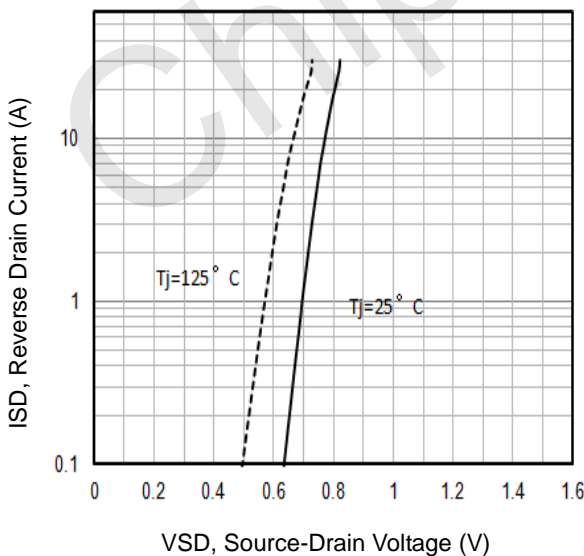

Fig5. Typical Source-Drain Diode Forward Voltage

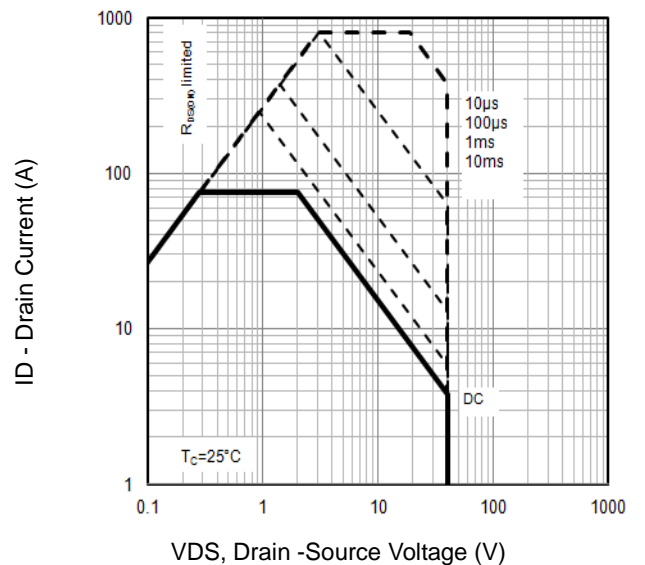

Fig6. Maximum Safe Operating Area



Typical Characteristics

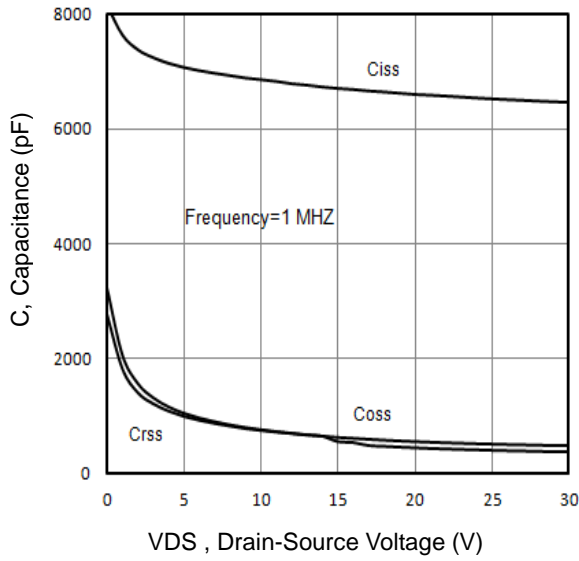

Fig7. Typical Capacitance Vs. Drain-Source Voltage

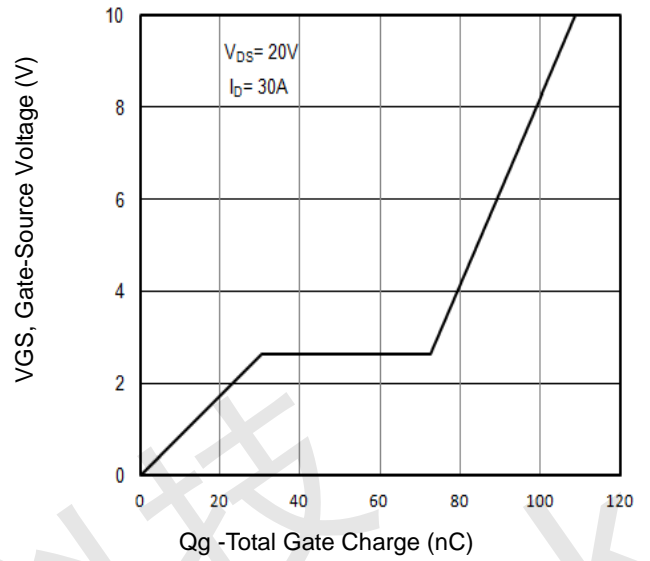

Fig8. Typical Gate Charge Vs. Gate-Source Voltage

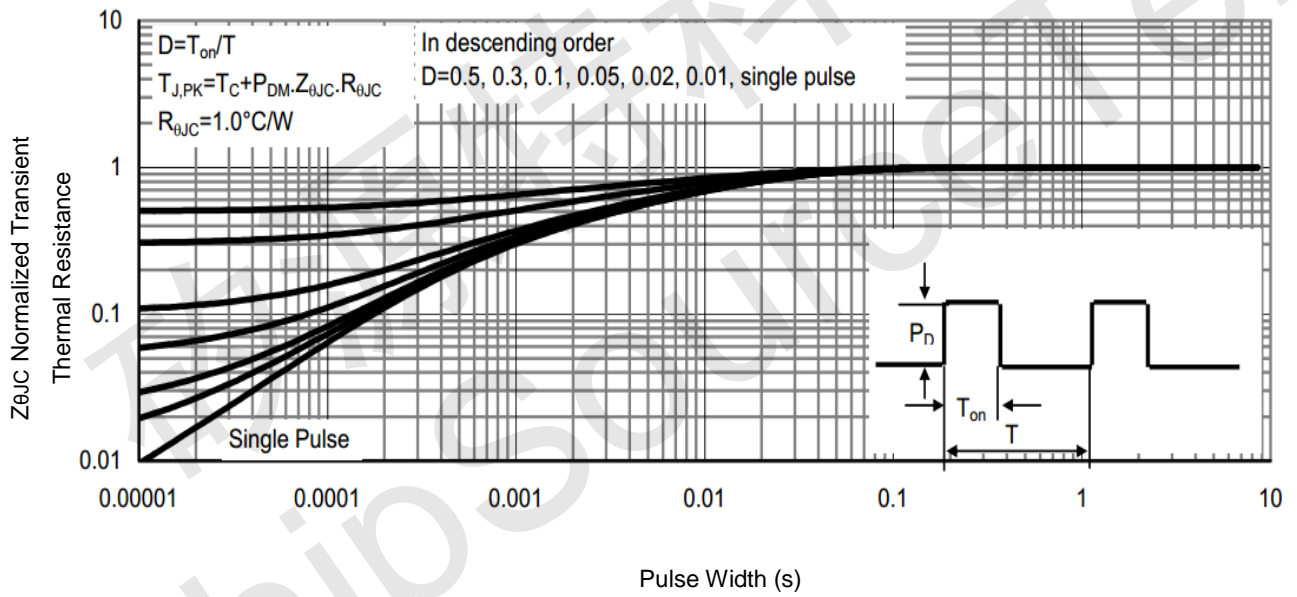

Fig9. Normalized Maximum Transient Thermal Impedance

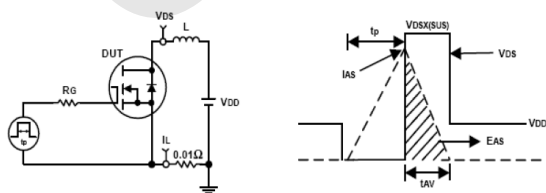

Fig10. Unclamped Inductive Test Circuit and waveforms

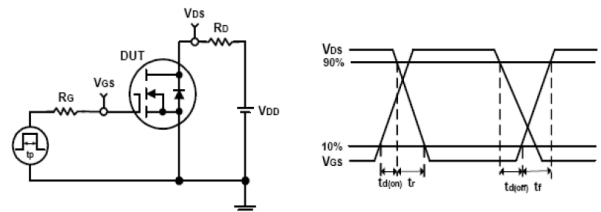
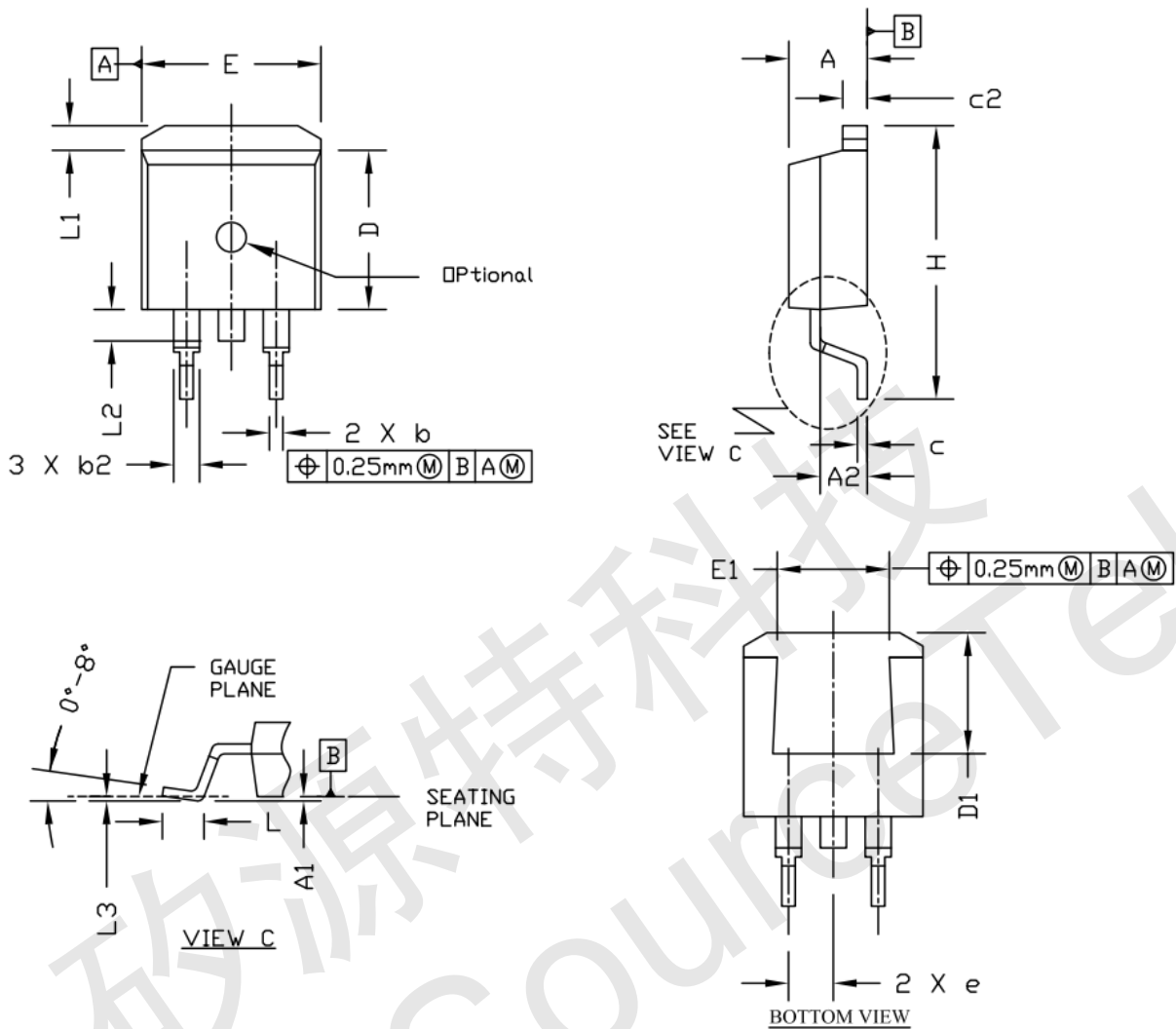

Fig11. Switching Time Test Circuit and waveforms



TO-263 Package Outline Data



Symbol	Dimensions (unit: mm)		
	Min	Typ	Max
A	4.400	4.570	4.700
A1	0.000	0.100	0.200
A2	2.300	2.400	2.500
b	0.700	0.800	0.900
b2	1.200	1.270	1.360
c	0.381	0.500	0.737
c2	1.220	1.300	1.350
D	8.600	9.200	9.300
D1	6.860		
e	2.540 BSC		
E	9.780	9.880	10.260
E1	6.225		
H	14.700	15.100	15.500
L	2.000	2.550	2.750
L1	1.000	1.200	1.400
L2	1.300	1.600	1.700
L3	0.255 BSC		

Notes:

1. Refer to JEDEC TO-263 variation AB
2. Dimension "D" & "E" do NOT include mold flash, mold flash shall not exceed 0.127mm per side.