



## Low power consumption, high performance 150mA LDO

### XYT2112 General Description

The XYT2112-XX is low power consumption very low 2uA ground current, high performance 150mA LDO . The family uses an advanced CMOS process and a PMOSFET pass device to achieve fast start-up, with high output voltage accuracy . The XYT2112-XX is stable with a 10.0μF ceramic output capacitor, and uses a precision voltage reference and feedback loop to achieve a worst-case accuracy of 1% over all load, line, process, and temperature variations. It is fully specified from  $T_J = -40^{\circ}\text{C}$  to  $+125^{\circ}\text{C}$  and is offered in a SOT89-3 , SOT23-3 package

### XYT2112 Features

- Wide Input Voltage Range: 2V to 30V
- Up to 150mA Load Current
- Very Low  $I_Q$ : 2μA@Typ
- High PSRR: 75dB@100Hz; 51dB@1KHz
- Ultra Low Dropout: 650mV at 150mA Load @ $V_{OUT}=5V$
- Short current protection:60mA
- Excellent Load/Line Transient Response
- Line Regulation: 0.05% typical
- Package: SOT89-3, SOT23-3

### XYT2112 Mark Specification Label

Part No.		$V_{OUT}$
XYT2112-30		3.0V
XYT2112-33		3.3V
XYT2112-50		5.0V



## XYT2112 Pin Configuration

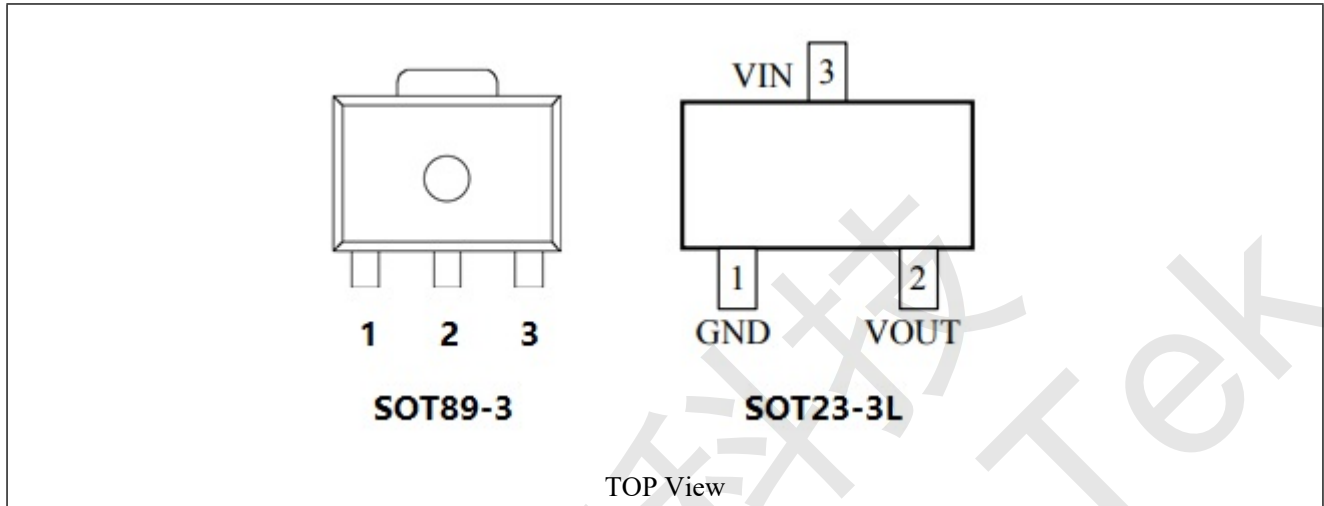

## XYT2112 Pin Function

Pin No.		Pin Name	Pin Function
SOT89-3	SOT23-5		
1	1	GND	Ground.
2	2	IN	Supply input pin. Must be closely decoupled to GND with a 1 $\mu$ F or greater ceramic capacitor.
3	3	OUT	Output pin. Bypass a 1 $\mu$ F ceramic capacitor from this pin to ground.
	4	NC	No connection.
	5	NC	No connection.



## XYT2112 Block Diagram

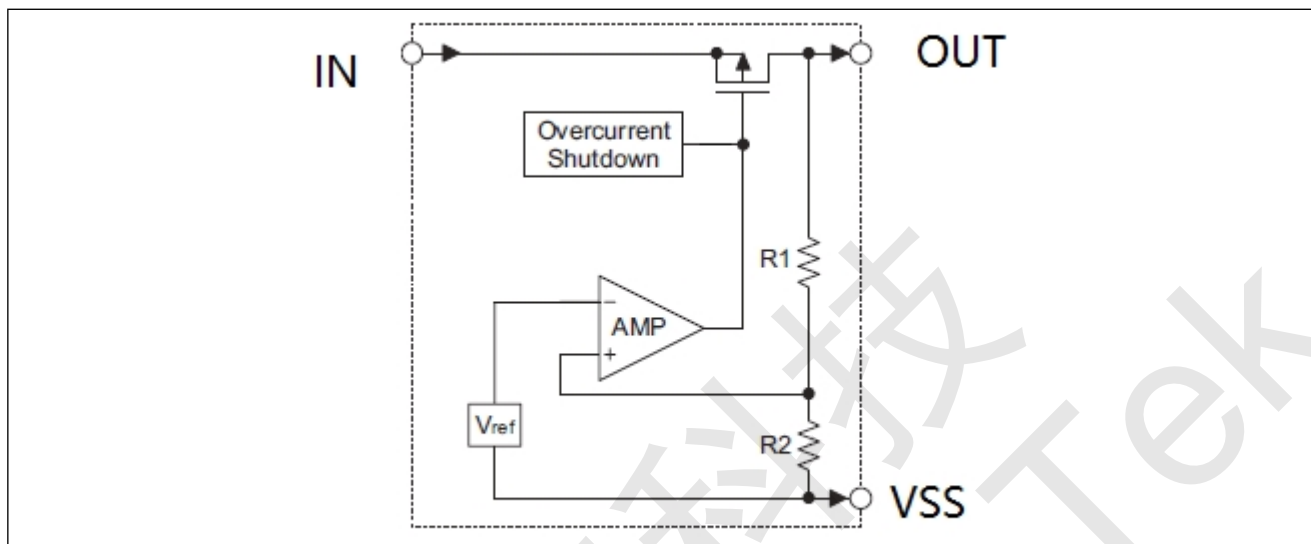

### Input Capacitor

A 1 $\mu$ F-10 $\mu$ F ceramic capacitor is recommended to connect between  $V_{IN}$  and GND pins to decouple input power supply glitch and noise. The amount of the capacitance may be increased without limit. This input capacitor must be located as close as possible to the device to assure input stability and less noise. For PCB layout, a wide copper trace is required for both  $V_{IN}$  and GND.

### Output Capacitor

An output capacitor is required for the stability of the LDO. The recommended output capacitance is from 1 $\mu$ F to 10 $\mu$ F, Equivalent Series Resistance (ESR) is from 5m $\Omega$  to 100m $\Omega$ , and temperature characteristics are X7R or X5R. Higher capacitance values help to improve load/line transient response. The output capacitance may be increased to keep low undershoot/overshoot. Place output capacitor as close as possible to OUT and GND pins.

### Low Quiescent Current

The XYT2112-XX, consuming only around 2 $\mu$ A for all input range and output loading, provides great power saving in portable and low power applications.

### Short Current Limit Protection

When output current at the OUT pin is higher than current limit threshold or the OUT pin is short-circuit to GND, the short current limit protection will be triggered and clamp the output current to approximately 100mA to prevent over-current and to protect the regulator from damage due to overheating.



### XYT2112 Absolute Maximum Ratings

Parameter	Rating		Unit
IN Voltage	-0.3 to 36		V
Maximum Power Dissipation	SOT89-3	700	mw
	SOT23-3	500	
Operating Junction Temperature	-40 to 125		°C
Storage Temperature	-65 to 150		°C
Lead Temperature (Soldering, 10 sec)	300		°C

### XYT2112 Electrical Characteristics

( $V_{IN} = V_{EN} = 7V$ ,  $T_A = 27^\circ C$  unless otherwise noted)

PARAMETER	SYMBOL	TEST CONDITIONS	MIN	TYP	MAX	UNIT
Input Voltage Operation Range	$V_{IN}$		3		30	V
Dropout Voltage	$V_{drop}$	$V_{OUT} = 5V, I_{OUT} = 150mA$		650	780	mV
		$V_{OUT} = 5V, I_{OUT} = 100mA$		400	530	
DC Supply Quiescent Current	$I_Q$			2		$\mu A$
Regulated Output Voltage	$V_{OUT}$	$I_{OUT} = 1mA, -40^\circ C \leq T_A \leq 85^\circ C$	-1		1	%
Output Voltage Line Regulation		$V_{IN} = V_{OUT} + 1V$ to 30V, $I_{OUT} = 10mA$		0.05		%
Output Voltage Load Regulation		$I_{OUT}$ from 0mA to 150mA		0.2		%
Maximum Output Current		$V_{IN} = V_{OUT} + 1V$	150			mA
Short Current Protection		OUT short to GND		60		mA

Note: Production test at  $+25^\circ C$ . Specifications over the temperature range are guaranteed by design and characterization.

### XYT2112 Application Circuits

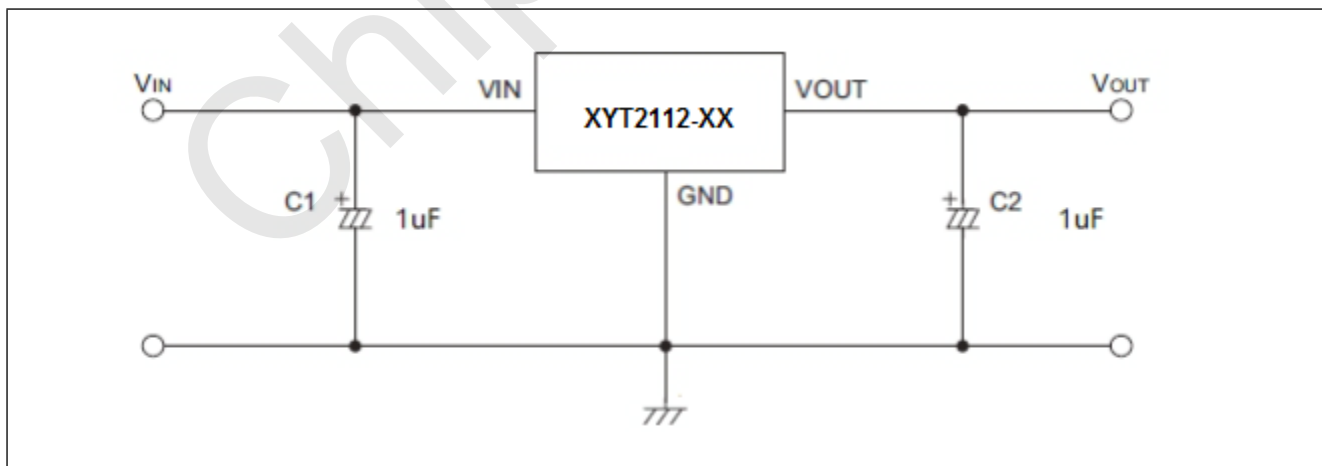



### XYT2112 Package Dimension

SOT89-3

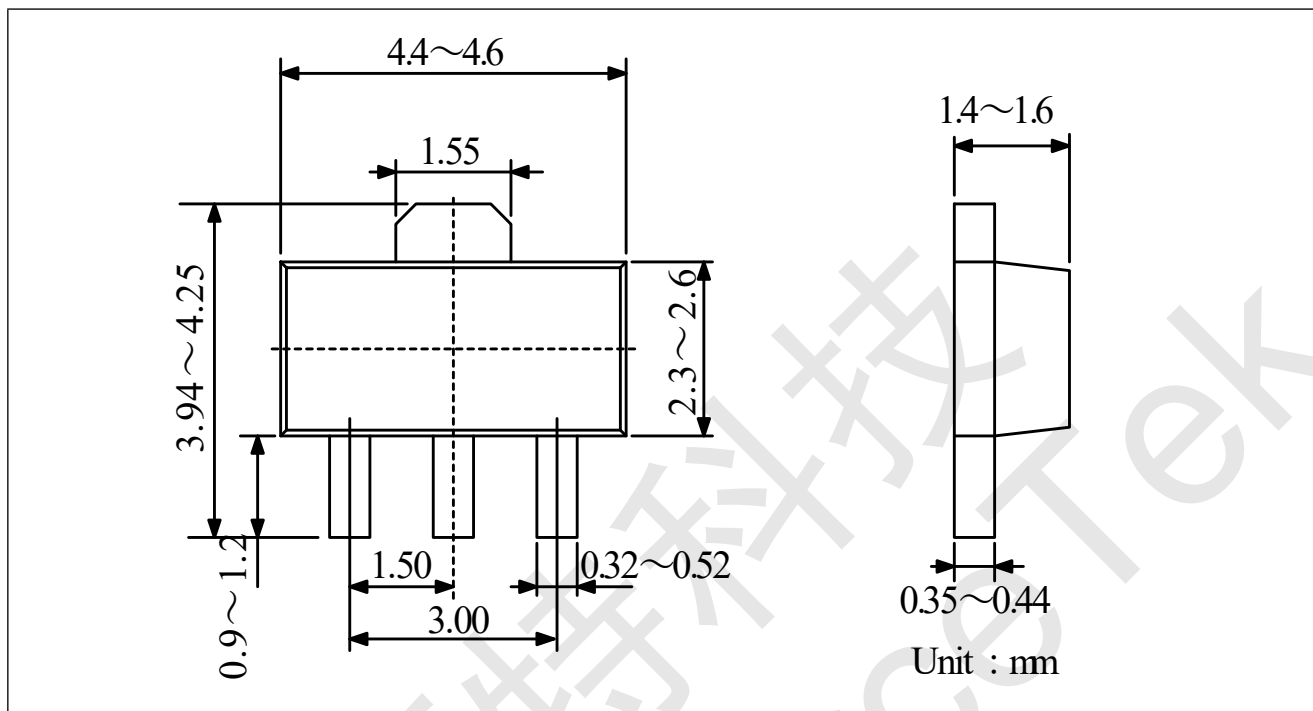

SOT23-3L

