



TX73XXM series

250mA Low Power LDO

Features

- Low power consumption
- Low voltage drop
- Low temperature coefficient
- Ultra low quiescent current: 2 μ A(typ.)
- High input voltage (up to 15V)
- Maximum output current: 250mA
- Output voltage accuracy: tolerance \pm 2%
- TO92, SOT89, SOT23-3 and SOT23 package

Applications

- Battery-powered equipment
- Communication equipment
- Audio/Video equipment

General Description

The TX73XXM series is a set of three-terminal low power high voltage regulators implemented in CMOS technology. They allow input voltages as high as 15V. The series features extremely low quiescent current which is typically 2 μ A. They are available with several fixed output voltages ranging from 1.5V to 5.0V. CMOS technology ensures low voltage drop and low quiescent current. Although designed primarily as fixed voltage regulators, these devices can be used with external components to obtain variable voltages and currents.

Selection Table

Part No.	Output Voltage	Package	Marking
TX7315Mxx	1.5V	TO92 SOT89 SOT23-3 SOT23	73XX-A(for TO92) 73XX-A(for SOT89) 3XX(for SOT23-3) 3XX(for SOT23)
TX7318Mxx	1.8V		
TX7325Mxx	2.5V		
TX7328Mxx	2.8V		
TX7330Mxx	3.0V		
TX7333Mxx	3.3V		
TX7336Mxx	3.6V		
TX7340Mxx	4.0V		
TX7344Mxx	4.4V		
TX7350Mxx	5.0V		

Order Information

TX73①②③④⑤

Designator	Symbol	Description
① ②	Integer	Output Voltage(1.5~5.0V)
③	M	Standard
④	T	Package:TO-92
	P	Package:SOT89-3
	M	Package:SOT23-3
	N	Package:SOT23
⑤	R	RoHS / Pb Free
	G	Halogen Free



TX73XXM series

250mA Low Power LDO

Block Diagram

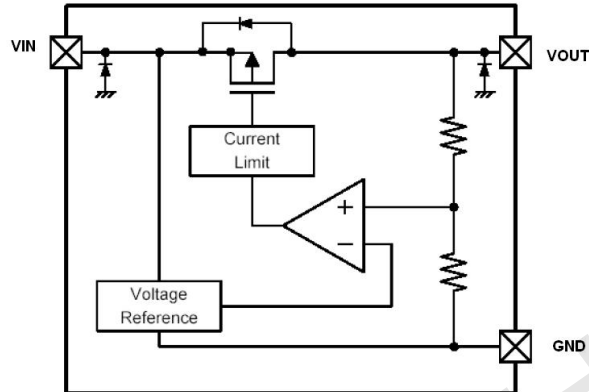

*Diodes inside the circuit are an ESD protection diode and a parasitic diode.

Pin Assignment

SOT23 and SOT23-3 (Top View)

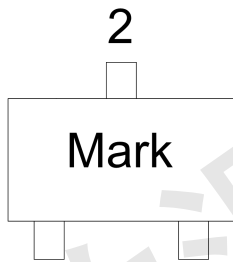

1 3
SOT89 (Top View)



1 2 3
TO92 (Top View)



Table1: TX73XXMNR/TX73XXMMR series (SOT23/SOT23-3PKG)

PIN NO.	PIN NAME	FUNCTION
1	GND	GND pin
2	VIN	Input voltage pin
3	VOUT	Output voltage pin

Table2: TX73XXMPR series (SOT89 PKG)

PIN NO.	PIN NAME	FUNCTION
1	GND	GND pin
2	VIN	Input voltage pin
3	VOUT	Output voltage pin

Table3: TX73XXMTR series (TO92 PKG)

PIN NO.	PIN NAME	FUNCTION
1	GND	GND pin
2	VIN	Input voltage pin
3	VOUT	Output voltage pin



TX73XXM series

250mA Low Power LDO

Absolute Maximum Ratings

Supply Voltage-0.3V to 18V Storage Temperature-50°C to 125°C
Operating Temperature-30°C to 85°C

Note: These are stress ratings only. Stresses exceeding the range specified under “Absolute Maximum Ratings” may cause substantial damage to the device. Functional operation of this device at other conditions beyond those listed in the specification is not implied and prolonged exposure to extreme conditions may affect device reliability.

Thermal Information

Symbol	Parameter	Package	Max.	Unit
θ_{JA}	Thermal Resistance (Junction to Ambient) (Assume no ambient airflow, no heat sink)	SOT23	500	°C/W
		SOT89	200	°C/W
		TO92	200	°C/W
P_D	Power Dissipation	SOT23	0.20	W
		SOT89	0.50	W
		TO92	0.50	W

Note: P_D is measured at $T_a = 25^\circ\text{C}$

Electrical Characteristics

TX7315Mxx, +1.5V Output Type

Symbol	Parameter	Test Conditions		Min.	Typ.	Max.	Unit
		V_{IN}	Conditions				
V_{OUT}	Output Voltage	3.5V	$I_{OUT}=40\text{mA}$	1.47	1.50	1.53	V
I_{OUT}	Output Current	3.5V	-	-	250	-	mA
ΔV_{OUT}	Load Regulation	3.5V	$1\text{mA} \leq I_{OUT} \leq 60\text{mA}$	-	45	90	mV
V_{DIF}	Voltage Drop(Note)	-	$I_{OUT}=40\text{mA}, \Delta V_{OUT}=2\%$	-	650	750	mV
I_{SS}	Current Consumption	3.5V	No load	-	2.0	3.0	μA
$\frac{\Delta V_{OUT}}{\Delta V_{IN} \times V_{OUT}}$	Line Regulation	-	$2.5\text{V} \leq V_{IN} \leq 12\text{V}$ $I_{OUT}=40\text{mA}$	-	0.2	-	%/V
V_{IN}	Input Voltage	-	-	-	-	15	V
$\frac{\Delta V_{OUT}}{\Delta T_a}$	Temperature Coefficient	3.5V	$I_{OUT}=40\text{mA}$ $-40^\circ\text{C} < T_a < 85^\circ\text{C}$	-	± 0.5	-	mV/°C

Note: Dropout voltage is defined as the input voltage minus the output voltage that produces a 2% change in the output voltage from the value at $V_{IN} = V_{OUT} + 1\text{V}$ with a fixed load.



TX73XXM series

250mA Low Power LDO

TX7318Mxx, +1.8V Output Type

Symbol	Parameter	Test Conditions		Min.	Typ.	Max.	Unit
		V _{IN}	Conditions				
V _{OUT}	Output Voltage	3.8V	I _{OUT} =10mA	1.764	1.800	1.836	V
I _{OUT}	Output Current	3.8V	-	-	250	-	mA
ΔV _{OUT}	Load Regulation	3.8V	1mA ≤ I _{OUT} ≤ 60mA	-	45	90	mV
V _{DIF}	Voltage Drop(Note)	-	I _{OUT} =40mA, ΔV _{OUT} =2%	-	620	720	mV
I _{SS}	Current Consumption	3.8V	No load	-	2.0	3.0	μA
$\frac{\Delta V_{OUT}}{\Delta V_{IN} \times V_{OUT}}$	Line Regulation	-	2.8V ≤ V _{IN} ≤ 12V I _{OUT} =40mA	-	0.2	-	%/V
V _{IN}	Input Voltage	-	-	-	-	15	V
$\frac{\Delta V_{OUT}}{\Delta T_a}$	Temperature Coefficient	3.8V	I _{OUT} =10mA -40°C < T _a < 85°C	-	±0.5	-	mV/°C

Note: Dropout voltage is defined as the input voltage minus the output voltage that produces a 2% change in the output voltage from the value at V_{IN} = V_{OUT}+1V with a fixed load.

TX7325Mxx, +2.5V Output Type

Symbol	Parameter	Test Conditions		Min.	Typ.	Max.	Unit
		V _{IN}	Conditions				
V _{OUT}	Output Voltage	4.5V	I _{OUT} =40mA	2.45	2.500	2.55	V
I _{OUT}	Output Current	4.5V	-	-	250	-	mA
ΔV _{OUT}	Load Regulation	4.5V	1mA ≤ I _{OUT} ≤ 60mA	-	45	90	mV
V _{DIF}	Voltage Drop(Note)	-	I _{OUT} =40mA, ΔV _{OUT} =2%	-	550	650	mV
I _{SS}	Current Consumption	4.5V	No load	-	2.0	3.0	μA
$\frac{\Delta V_{OUT}}{\Delta V_{IN} \times V_{OUT}}$	Line Regulation	-	3.5V ≤ V _{IN} ≤ 12V I _{OUT} =40mA	-	0.2	-	%/V
V _{IN}	Input Voltage	-	-	-	-	15	V
$\frac{\Delta V_{OUT}}{\Delta T_a}$	Temperature Coefficient	4.5V	I _{OUT} =40mA -40°C < T _a < 85°C	-	±0.5	-	mV/°C

Note: Dropout voltage is defined as the input voltage minus the output voltage that produces a 2% change in the output voltage from the value at V_{IN} = V_{OUT}+1V with a fixed load.



TX73XXM series

250mA Low Power LDO

TX7328Mxx, +2.8V Output Type

Symbol	Parameter	Test Conditions		Min.	Typ.	Max.	Unit
		V _{IN}	Conditions				
V _{OUT}	Output Voltage	4.8V	I _{OUT} =10mA	2.744	2.800	2.856	V
I _{OUT}	Output Current	4.8V	-	-	250	-	mA
ΔV _{OUT}	Load Regulation	4.8V	1mA ≤ I _{OUT} ≤ 60mA	-	45	90	mV
V _{DIF}	Voltage Drop(Note)	-	I _{OUT} =40mA, ΔV _{OUT} =2%	-	520	620	mV
I _{SS}	Current Consumption	4.8V	No load	-	2.0	3.0	μA
$\frac{\Delta V_{OUT}}{\Delta V_{IN} \times V_{OUT}}$	Line Regulation	-	3.8V ≤ V _{IN} ≤ 12V I _{OUT} =40mA	-	0.2	-	%/V
V _{IN}	Input Voltage	-	-	-	-	15	V
$\frac{\Delta V_{OUT}}{\Delta T_a}$	Temperature Coefficient	4.8V	I _{OUT} =10mA -40°C < T _a < 85°C	-	±0.5	-	mV/°C

Note: Dropout voltage is defined as the input voltage minus the output voltage that produces a 2% change in the output voltage from the value at V_{IN} = V_{OUT}+1V with a fixed load.

TX7330Mxx, +3.0V Output Type

Symbol	Parameter	Test Conditions		Min.	Typ.	Max.	Unit
		V _{IN}	Conditions				
V _{OUT}	Output Voltage	5V	I _{OUT} =40mA	2.94	3.00	3.06	V
I _{OUT}	Output Current	5V	-	-	250	-	mA
ΔV _{OUT}	Load Regulation	5V	1mA ≤ I _{OUT} ≤ 60mA	-	45	90	mV
V _{DIF}	Voltage Drop(Note)	-	I _{OUT} =40mA, ΔV _{OUT} =2%	-	480	580	mV
I _{SS}	Current Consumption	5V	No load	-	2.0	3.0	μA
$\frac{\Delta V_{OUT}}{\Delta V_{IN} \times V_{OUT}}$	Line Regulation	-	4V ≤ V _{IN} ≤ 12V I _{OUT} =40mA	-	0.2	-	%/V
V _{IN}	Input Voltage	-	-	-	-	15	V
$\frac{\Delta V_{OUT}}{\Delta T_a}$	Temperature Coefficient	5V	I _{OUT} =40mA -40°C < T _a < 85°C	-	±0.5	-	mV/°C

Note: Dropout voltage is defined as the input voltage minus the output voltage that produces a 2% change in the output voltage from the value at V_{IN} = V_{OUT}+1V with a fixed load.



TX73XXM series

250mA Low Power LDO

TX7333Mxx, +3.3V Output Type

Symbol	Parameter	Test Conditions		Min.	Typ.	Max.	Unit
		V _{IN}	Conditions				
V _{OUT}	Output Voltage	5.3V	I _{OUT} =40mA	3.234	3.300	3.366	V
I _{OUT}	Output Current	5.3V	-	-	250	-	mA
ΔV _{OUT}	Load Regulation	5.3V	1mA ≤ I _{OUT} ≤ 60mA	-	45	90	mV
V _{DIF}	Voltage Drop(Note)	-	I _{OUT} =40mA, ΔV _{OUT} =2%	-	440	540	mV
I _{SS}	Current Consumption	5.3V	No load	-	2.0	3.0	μA
$\frac{\Delta V_{OUT}}{\Delta V_{IN} \times V_{OUT}}$	Line Regulation	-	4.3V ≤ V _{IN} ≤ 12V I _{OUT} =40mA	-	0.2	-	%/V
V _{IN}	Input Voltage	-	-	-	-	15	V
$\frac{\Delta V_{OUT}}{\Delta T_a}$	Temperature Coefficient	5.3V	I _{OUT} =40mA -40°C < T _a < 85°C	-	±0.5	-	mV/°C

Note: Dropout voltage is defined as the input voltage minus the output voltage that produces a 2% change in the output voltage from the value at V_{IN} = V_{OUT}+1V with a fixed load.

TX7336Mxx, +3.6V Output Type

Symbol	Parameter	Test Conditions		Min.	Typ.	Max.	Unit
		V _{IN}	Conditions				
V _{OUT}	Output Voltage	5.6V	I _{OUT} =40mA	3.528	3.600	3.672	V
I _{OUT}	Output Current	5.6V	-	-	250	-	mA
ΔV _{OUT}	Load Regulation	5.6V	1mA ≤ I _{OUT} ≤ 60mA	-	45	90	mV
V _{DIF}	Voltage Drop(Note)	-	I _{OUT} =40mA, ΔV _{OUT} =2%	-	400	500	mV
I _{SS}	Current Consumption	5.6V	No load	-	2.0	3.0	μA
$\frac{\Delta V_{OUT}}{\Delta V_{IN} \times V_{OUT}}$	Line Regulation	-	4.6V ≤ V _{IN} ≤ 12V I _{OUT} =40mA	-	0.2	-	%/V
V _{IN}	Input Voltage	-	-	-	-	15	V
$\frac{\Delta V_{OUT}}{\Delta T_a}$	Temperature Coefficient	5.6V	I _{OUT} =40mA -40°C < T _a < 85°C	-	±0.5	-	mV/°C

Note: Dropout voltage is defined as the input voltage minus the output voltage that produces a 2% change in the output voltage from the value at V_{IN} = V_{OUT}+1V with a fixed load.



TX73XXM series

250mA Low Power LDO

TX7344Mxx, +4.4V Output Type

Symbol	Parameter	Test Conditions		Min.	Typ.	Max.	Unit
		V _{IN}	Conditions				
V _{OUT}	Output Voltage	6.4V	I _{OUT} =40mA	4.312	4.400	4.488	V
I _{OUT}	Output Current	6.4V	-	-	250	-	mA
ΔV _{OUT}	Load Regulation	6.4V	1mA ≤ I _{OUT} ≤ 60mA	-	45	90	mV
V _{DIF}	Voltage Drop(Note)	-	I _{OUT} =40mA, ΔV _{OUT} =2%	-	280	380	mV
I _{SS}	Current Consumption	6.4V	No load	-	2.0	3.0	μA
$\frac{\Delta V_{OUT}}{\Delta V_{IN} \times V_{OUT}}$	Line Regulation	-	5.4V ≤ V _{IN} ≤ 12V I _{OUT} =40mA	-	0.2	-	%/V
V _{IN}	Input Voltage	-	-	-	-	15	V
$\frac{\Delta V_{OUT}}{\Delta T_a}$	Temperature Coefficient	6.4V	I _{OUT} =40mA -40°C < T _a < 85°C	-	±0.5	-	mV/°C

Note: Dropout voltage is defined as the input voltage minus the output voltage that produces a 2% change in the output voltage from the value at V_{IN} = V_{OUT}+1V with a fixed load.

TX7350Mxx, +5.0V Output Type

Symbol	Parameter	Test Conditions		Min.	Typ.	Max.	Unit
		V _{IN}	Conditions				
V _{OUT}	Output Voltage	7V	I _{OUT} =40mA	4.9	5.00	5.1	V
I _{OUT}	Output Current	7V	-	-	250	-	mA
ΔV _{OUT}	Load Regulation	7V	1mA ≤ I _{OUT} ≤ 60mA	-	45	90	mV
V _{DIF}	Voltage Drop(Note)	-	I _{OUT} =40mA, ΔV _{OUT} =2%	-	200	300	mV
I _{SS}	Current Consumption	7V	No load	-	2.0	3.0	μA
$\frac{\Delta V_{OUT}}{\Delta V_{IN} \times V_{OUT}}$	Line Regulation	-	6V ≤ V _{IN} ≤ 12V I _{OUT} =40mA	-	0.2	-	%/V
V _{IN}	Input Voltage	-	-	-	-	15	V
$\frac{\Delta V_{OUT}}{\Delta T_a}$	Temperature Coefficient	7V	I _{OUT} =40mA -40°C < T _a < 85°C	-	±0.5	-	mV/°C

Note: Dropout voltage is defined as the input voltage minus the output voltage that produces a 2% change in the output voltage from the value at V_{IN} = V_{OUT}+1V with a fixed load.



Typical Performance Characteristics

(1) Output Voltage vs Input voltage

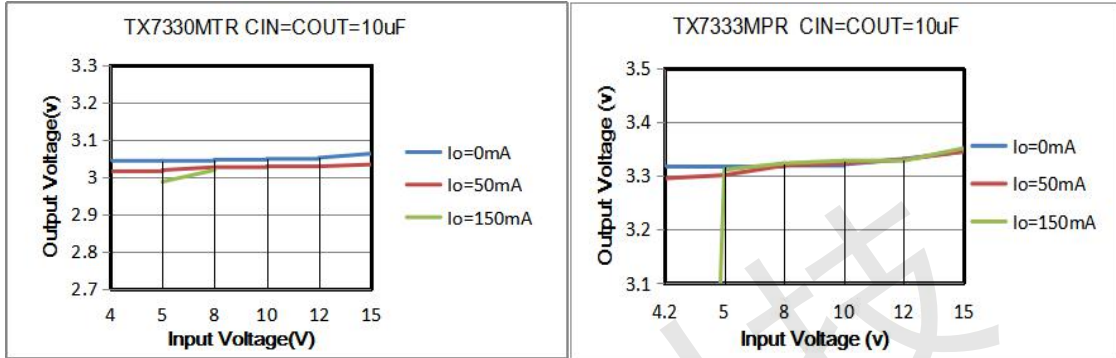

(2) Output Voltage vs. Output Current

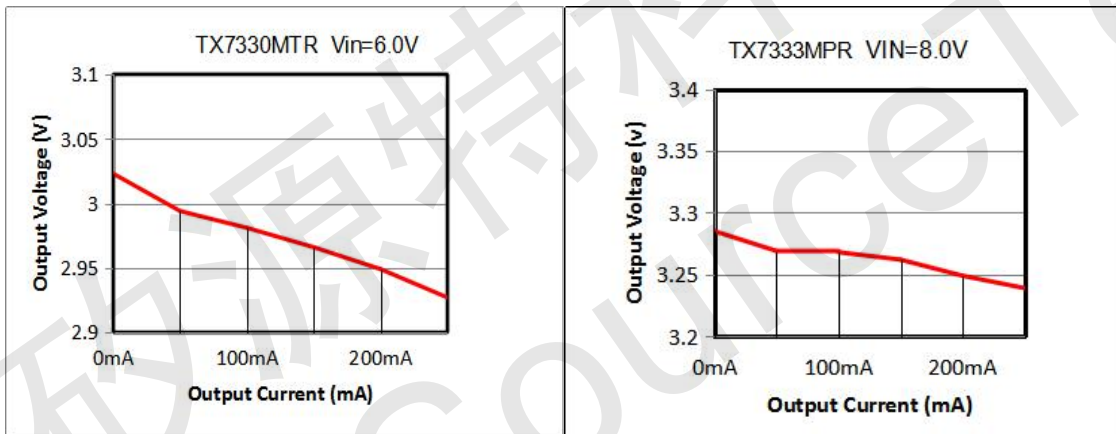

(3) Input Transient Response

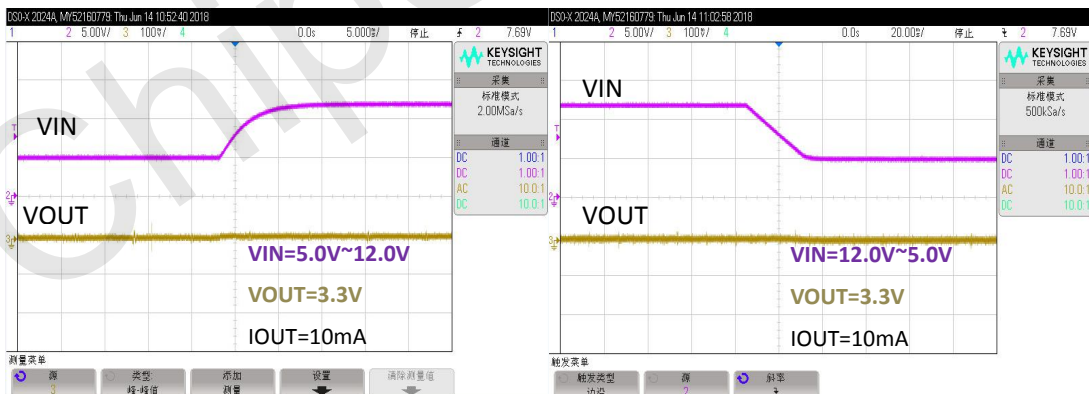



(4) Load Transient Response

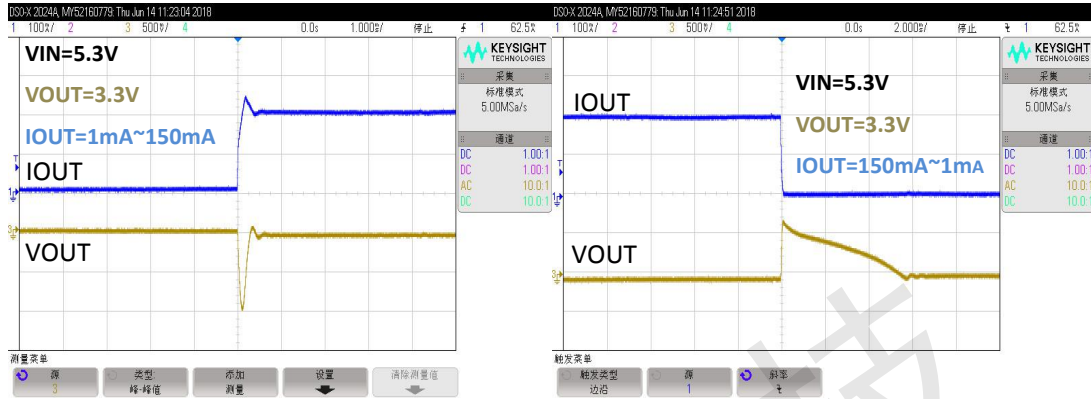

(5) MAX Output Current Vs. Input Voltage

TX7330MPR

Input Voltage	Max Output Current
6V	250mA
9V	200mA
12V	150mA
15V	100mA

TX7333MPR

Input Voltage	Max Output Current
6.3V	250mA
9V	200mA
12V	150mA
15V	100mA

TX7350MPR

Input Voltage	Max Output Current
8V	250mA
9V	200mA
12V	150mA
15V	100mA

- Note: 1. The Max Output Current is the typical value;
 2. In order to ensure that the best parameters can be achieved, the PCB is preferably provided with a large copper foil area to increase heat dissipation.



Application Circuits

Basic Circuits

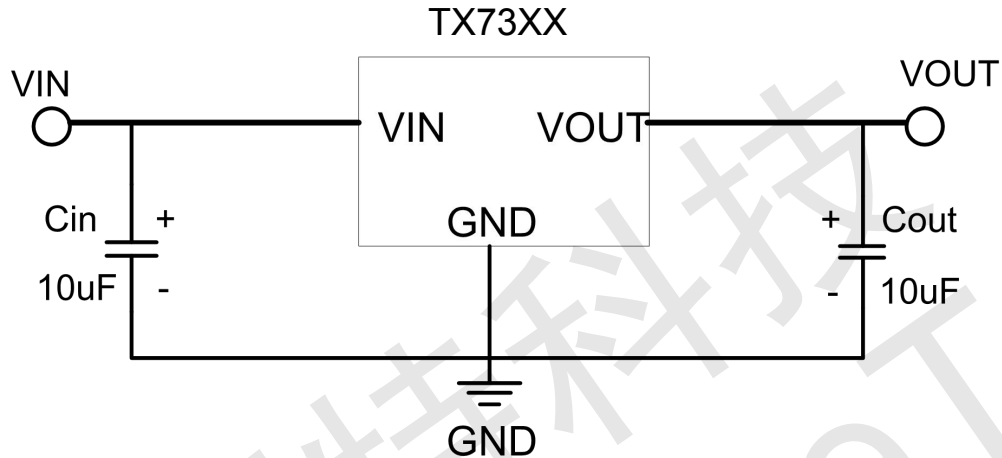

Note1: $C_{in}=C_{out}=10\mu F$. (10 μF Electrolytic capacitor is recommended).

Note2: If the input and output capacitors are ceramic, add a resistor at the input, as follows.

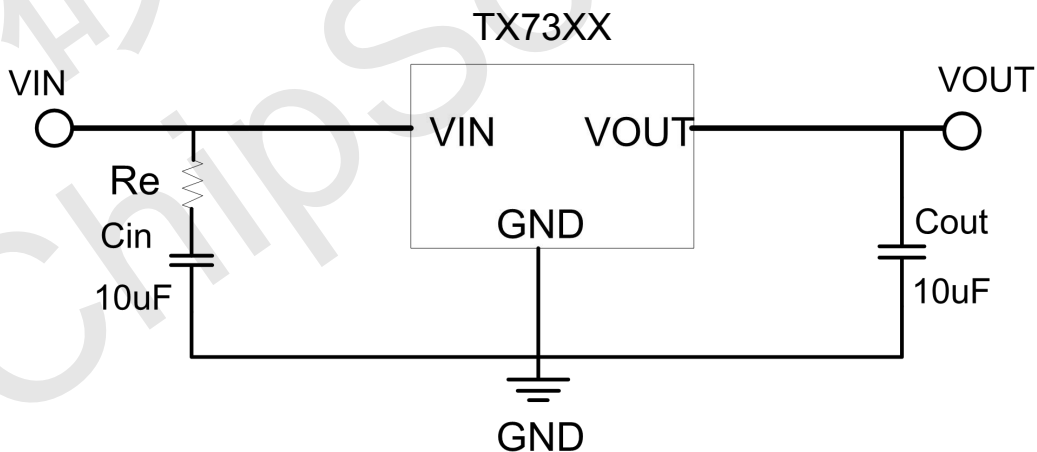

Note: $R_e = (1.2 \sim 1.8)\Omega$.



Package Information

3-pin TO92 Outline Dimensions

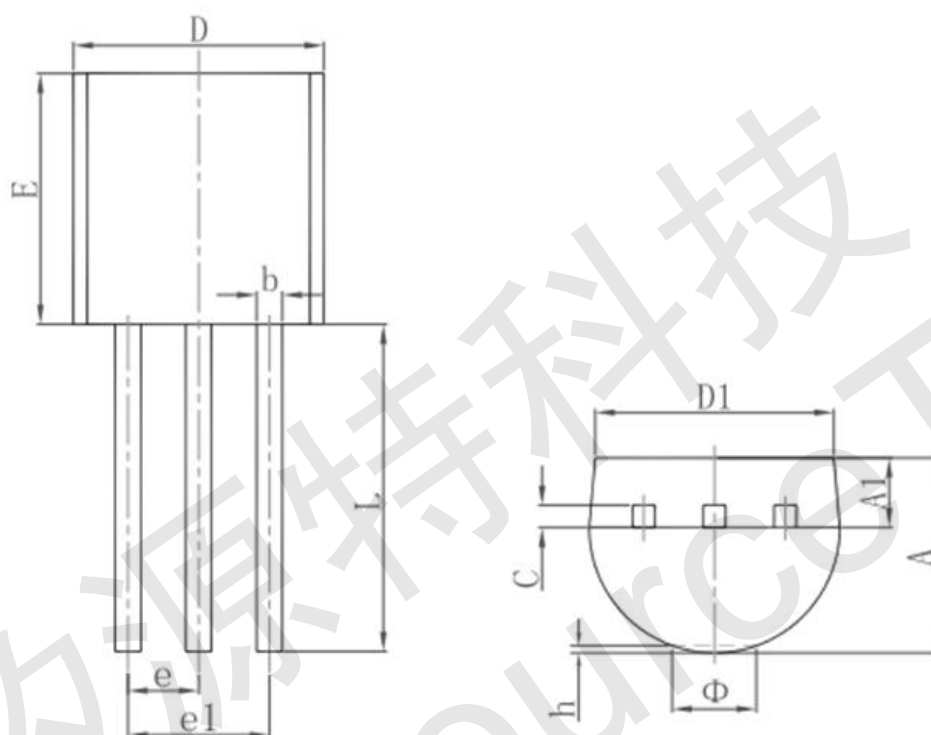

Symbol	Dimensions In Millimeters		Dimensions In Inches	
	Min.	Max.	Min.	Max.
A	3.300	3.700	0.130	0.146
A1	1.100	1.400	0.043	0.055
b	0.380	0.550	0.015	0.022
c	0.360	0.510	0.014	0.020
D	4.300	4.700	0.169	0.185
D1	3.430		0.135	
E	4.300	4.700	0.169	0.185
e	1.270 TYP.		0.050 TYP.	
e1	2.440	2.640	0.096	0.104
L	14.100	14.500	0.555	0.571
Φ		1.600		0.063
h	0.000	0.380	0.000	0.015



3-pin SOT89 Outline Dimensions

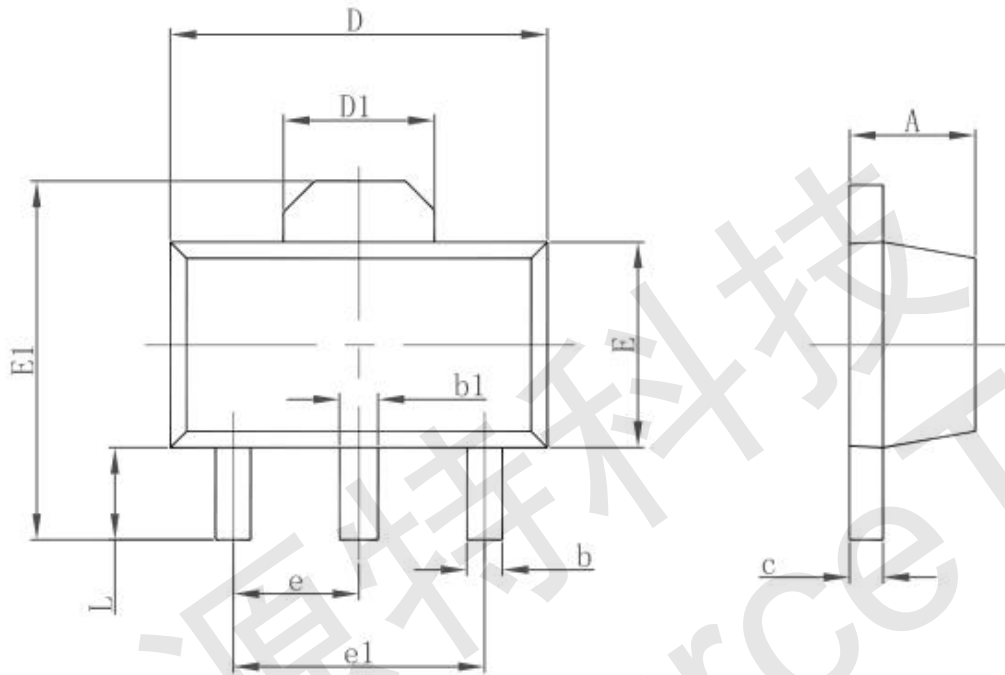

Symbol	Dimensions In Millimeters		Dimensions In Inches	
	Min.	Max.	Min.	Max.
A	1.400	1.600	0.055	0.063
b	0.320	0.520	0.013	0.020
b1	0.400	0.580	0.016	0.023
c	0.350	0.440	0.014	0.017
D	4.400	4.600	0.173	0.181
D1	1.550 REF.		0.061 REF.	
E	2.300	2.600	0.091	0.102
E1	3.940	4.250	0.155	0.167
e	1.500 TYP.		0.060 TYP.	
e1	3.000 TYP.		0.118 TYP.	
L	0.900	1.200	0.035	0.047



3-pin SOT23-3 Outline Dimensions

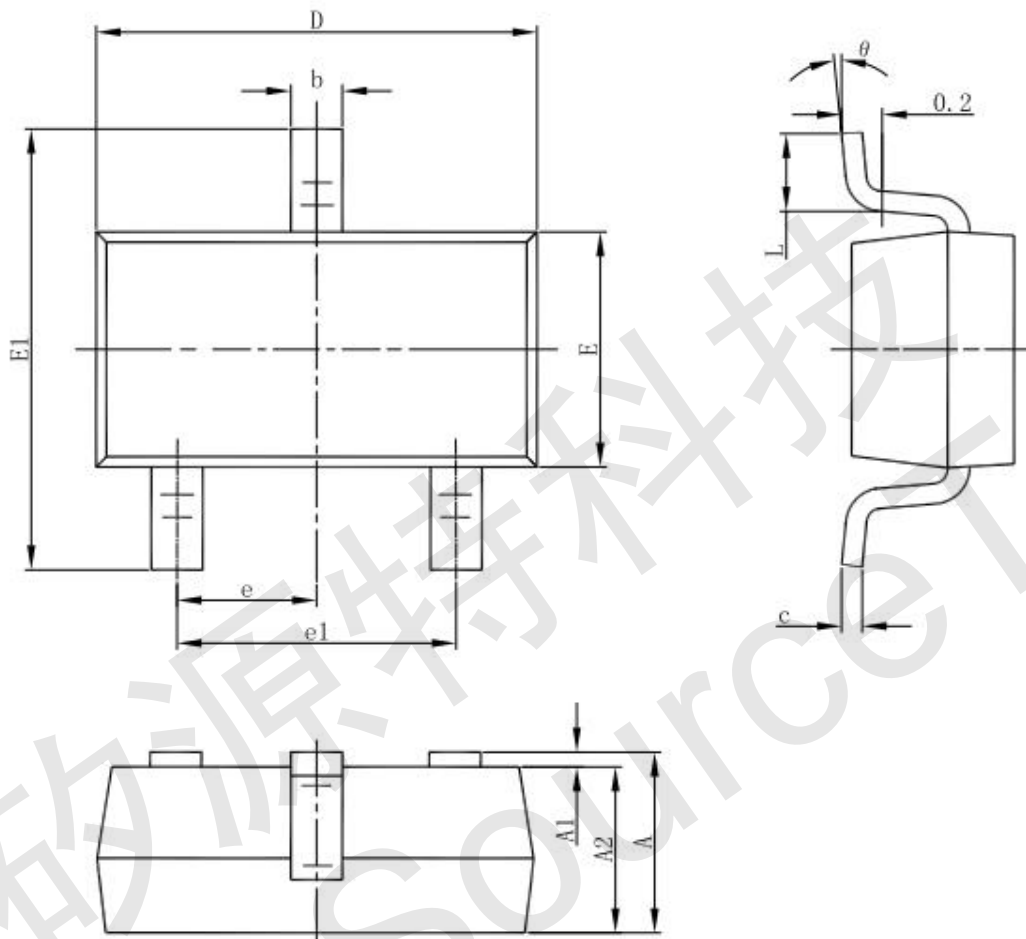

Symbol	Dimensions In Millimeters		Dimensions In Inches	
	Min	Max	Min	Max
A	1.050	1.250	0.041	0.049
A1	0.000	0.100	0.000	0.004
A2	1.050	1.150	0.041	0.045
b	0.300	0.500	0.012	0.020
c	0.100	0.200	0.004	0.008
D	2.820	3.020	0.111	0.119
E	1.500	1.700	0.059	0.067
E1	2.650	2.950	0.104	0.116
e	0.950(BSC)		0.037(BSC)	
e1	1.800	2.000	0.071	0.079
L	0.300	0.600	0.012	0.024
θ	0°	8°	0°	8°



3-pin SOT23 Outline Dimensions

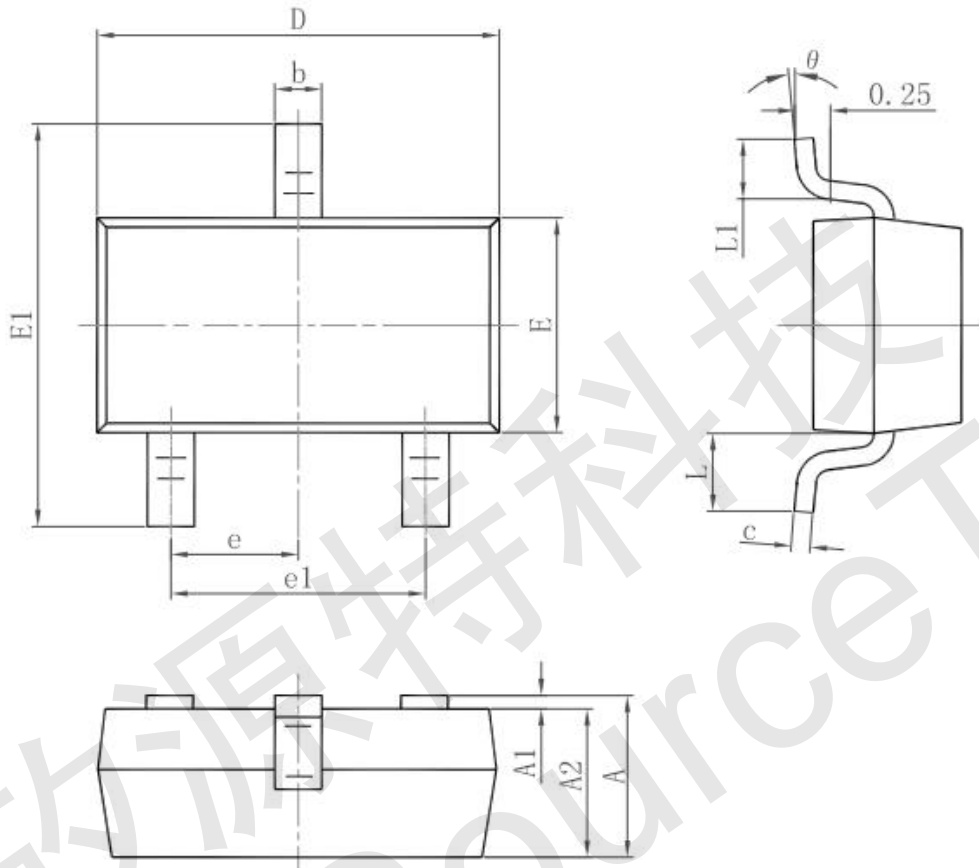

Symbol	Dimensions In Millimeters		Dimensions In Inches	
	Min.	Max.	Min.	Max.
A	0.900	1.150	0.035	0.045
A1	0.000	0.100	0.000	0.004
A2	0.900	1.050	0.035	0.041
b	0.300	0.500	0.012	0.020
c	0.080	0.150	0.003	0.006
D	2.800	3.000	0.110	0.118
E	1.200	1.400	0.047	0.055
E1	2.250	2.550	0.089	0.100
e	0.950 TYP.		0.037 TYP.	
e1	1.800	2.000	0.071	0.079
L	0.550 REF.		0.022 REF.	
L1	0.300	0.500	0.012	0.020
θ	0°	8°	0°	8°